

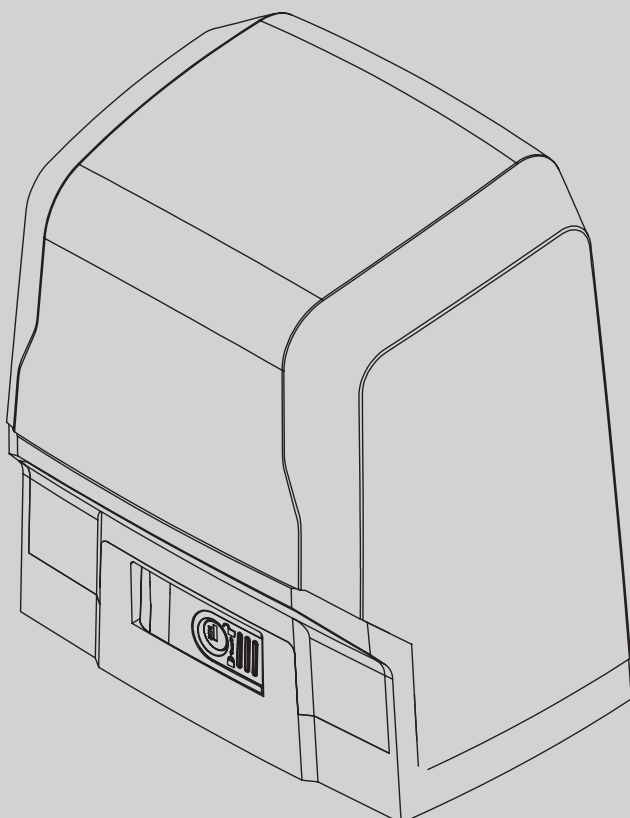

D812200 00100_03.06-11-15

ATTUATORE PER CANCELLI SCORREVOLI A CREMAGLIERA
ACTUATOR FOR RACK SLIDING GATES
ACTIONNEUR POUR PORTAILS COULISSANTS A CREMAILLERE
ANTRIEB FÜR ZAHNSTANGEN-SCHIEBETORE
SERVOMOTOR PARA CANCELAS CORREDERAS DE CREMALLERA
ACTUATOR VOOR SCHUIFHEKKEN MET TANDHEUGEL



ISTRUZIONI D'USO E DI INSTALLAZIONE
INSTALLATION AND USER'S MANUAL
INSTRUCTIONS D'UTILISATION ET D'INSTALLATION
INSTALLATIONS-UND GEBRAUCHSANLEITUNG
INSTRUCCIONES DE USO Y DE INSTALACION
INSTALLATIEVOORSCHRIFTEN

ARES BT A 1000

ARES BT A 1500



AZIENDA CON SISTEMA DI GESTIONE
INTEGRATO CERTIFICATO DA DNV
= UNI EN ISO 9001:2008 =
UNI EN ISO 14001:2004

Attenzione! Leggere attentamente le "Avvertenze" all'interno! **Caution!** Read "Warnings" inside carefully! **Attention!** Veuillez lire attentivement les Avertissements qui se trouvent à l'intérieur!
Achtung! Bitte lesen Sie aufmerksam die „Hinweise“ im Inneren! **¡Atención!** Leer atentamente las "Advertencias" en el interior! **Let op!** Lees de "Waarschuwingen" aan de binnenkant zorgvuldig!

INSTALLAZIONE VELOCE-QUICK INSTALLATION-INSTALLATION RAPIDE SCHNELLINSTALLATION-INSTALACIÓN RÁPIDA - SNELLE INSTALLATIE

D812200 00100_03

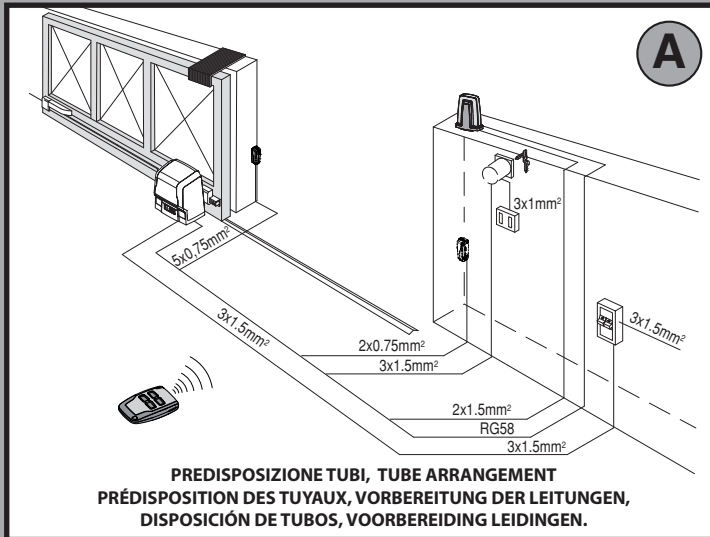

**PREDISPOSIZIONE TUBI, TUBE ARRANGEMENT
PRÉDISPOSITION DES TUYAUX, VORBEREITUNG DER LEITUNGEN,
DISPOSICIÓN DE TUBOS, VOORBEREIDING LEIDINGEN.**

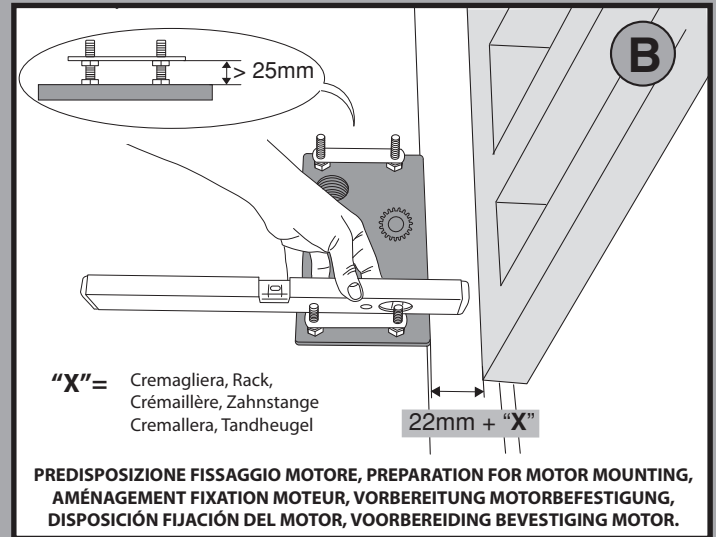

**PREDISPOSIZIONE FISSAGGIO MOTORE, PREPARATION FOR MOTOR MOUNTING,
AMÉNAGEMENT FIXATION MOTEUR, VORBEREITUNG MOTORBEFESTIGUNG,
DISPOSICIÓN FIJACIÓN DEL MOTOR, VOORBEREIDING BEVESTIGING MOTOR.**

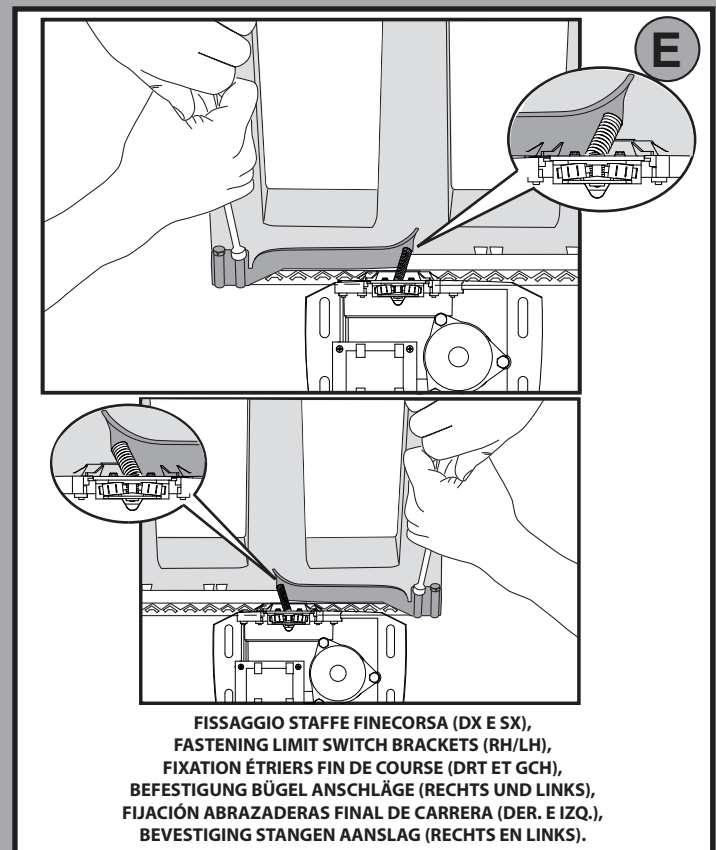
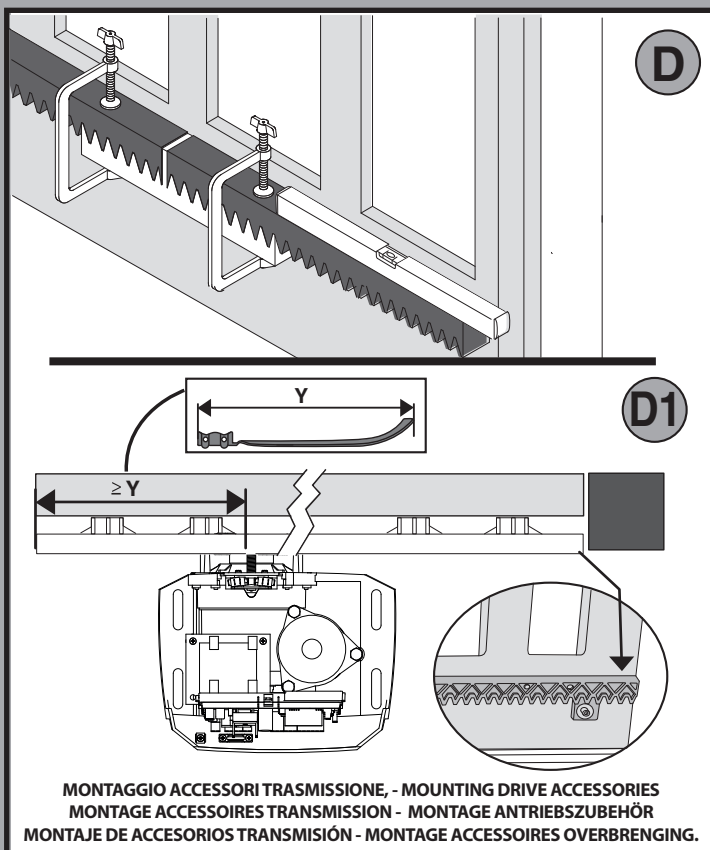
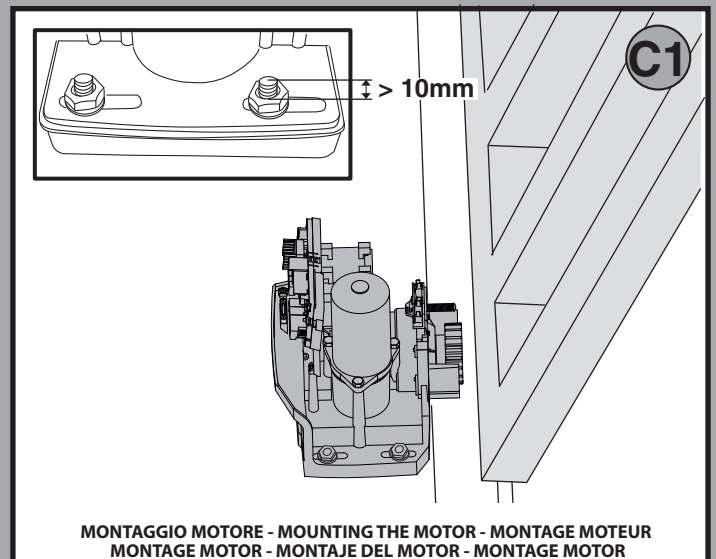
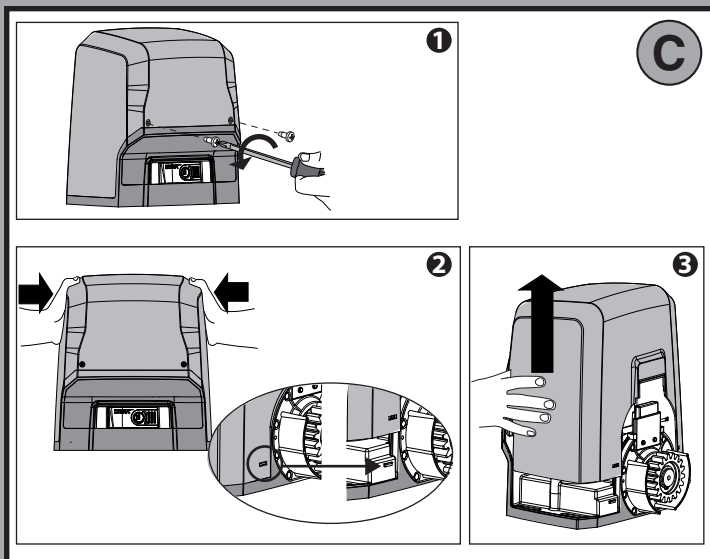

**MONTAGGIO ACCESSORI TRASMISSIONE, - MOUNTING DRIVE ACCESSORIES
MONTAGE ACCESSOIRES TRANSMISSION - MONTAGE ANTRIEBSZUBEHÖR
MONTAJE DE ACCESORIOS TRANSMISIÓN - MONTAGE ACCESSOIRES OVERBRENGING.**

**FISSAGGIO STAFFE FINECORSA (DX E SX),
FASTENING LIMIT SWITCH BRACKETS (RH/LH),
FIXATION ÉTRIERS FIN DE COURSE (DRT ET GCH),
BEFESTIGUNG BÜGEL ANSCHLÄGE (RECHTS UND LINKS),
FIJACIÓN ABRAZADERAS FINAL DE CARRERA (DER. E IZQ.),
BEVESTIGING STANGEN AANSLAG (RECHTS EN LINKS).**

COLLEGAMENTO MORSETTIERA, TERMINAL BOARD WIRING, CONNEXION PLAQUE À BORNES, ANSCHLUSS KLEMMLEISTE, CONEXIÓN TABLERO DE BORNES, AANSLUITING AANSLUITKAST.

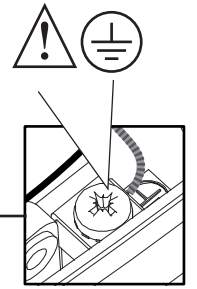
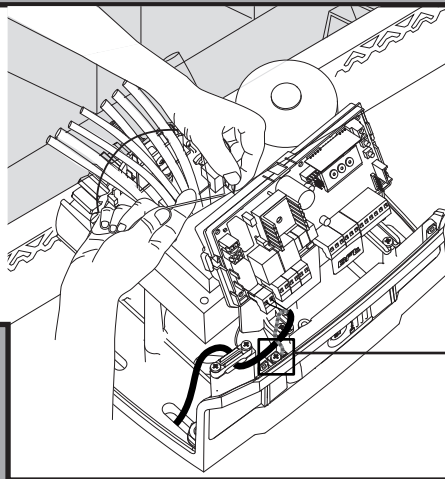
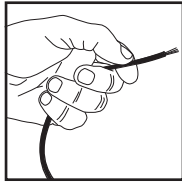
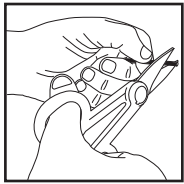

F

Antenna
Antenne
Antena
Antenne

Tasti programmazione,
Programming keys,
touches de programmation,
Programmierungstasten,
botones de programación,
Toetsen programmeur.

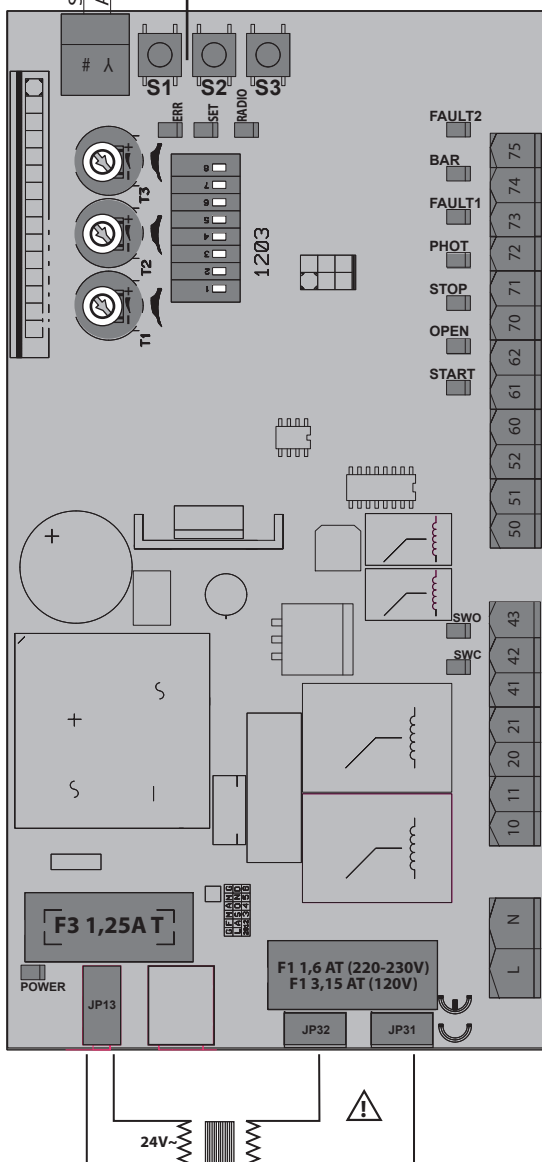

- FAULT 2
- BAR
- FAULT 1
- PHOT
- STOP
- COM
- OPEN
- START
- COM
- 24 VSafe
- 24V ~ (+)
- 24V ~ (-)
- SWO
- SWC
- + REF SWE
- 24V
-
- +
- N
- L

Sicurezze
Safety devices
Sécuritéés
Sicherheitsvorrichtungen
Dispositivos de seguridad
Veiligheden

Comandi / Commands
Commandes/Bedienelemente
Mandos/ Commando's

Alimentazione accessori
Accessories power supply
Alimentation des accessoires
Stromversorgung Zubehör
Alimentación accesorios
Voeding accessoires

Connettore finecorsa
Limit switch connector
Connecteur de fin de course
Steckverbindung Endschalter
Conector final de carrera
Connector eindaanslag

Lampeggiante / Blinker / Clignotant
Warnblinkleuchte / Bombilla / Knipperlicht

Motore / Motor / moteur
Motor /Eindaanslag/Encoder

Alimentazione / Power supply
Alimentation / Stromversorgung
Alimentación /Voeding

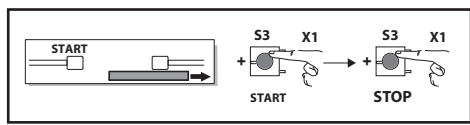

G

H

Collegamento di 1 coppia di fotocellule non verificate,
Connection of 1 pair of non-tested photocells,
Connexion 1 paire photocellules no vérifiées,
Anschluss von einem Paar nicht überprüften Fotozellen,
Conexión de 1 par fotocélulas no comprobadas,
Aansluiting van 1 paar fotocellen anders dan "trusted device".

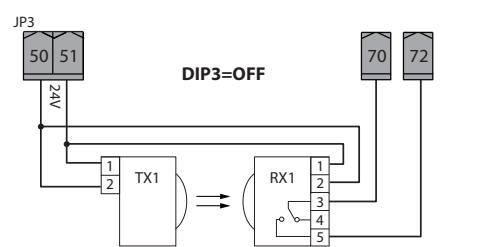

ITALIANO

ENGLISH

FRANÇAIS

DEUTSCH

ESPAÑOL

NEDERLANDS

**MEMORIZZAZIONE RADIOCOMANDO / MEMORIZING REMOTE CONTROLS / MÉMORISATION RADIOCOMMANDE
ABSPEICHERUNG DER FERNBEDIENUNG / MEMORIZACIÓN DEL RADIOMANDO / MEMORIZAÇÃO DO RADIOCOMANDO
MONTAJE DE ACCESORIOS TRANSMISIÓN - MONTAGE ACCESSOIRES OVERBRENGING.**

I

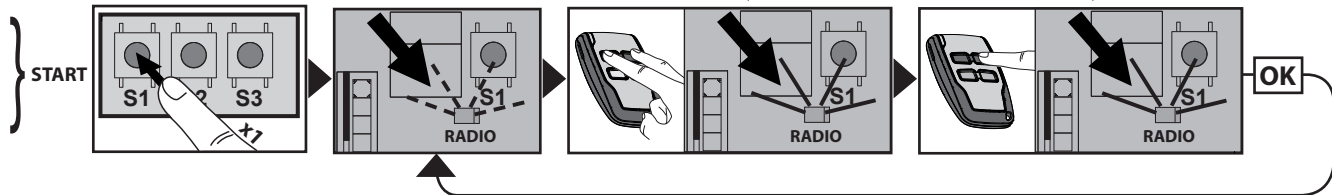

**REGOLAZIONE AUTOSSET, ADJUSTING AUTOSSET, RÉGLAGE AUTOSSET
EINSTELLUNG AUTOSSET, REGULACIÓN AUTOSSET, REGULACÃO AUTOSSET**

11

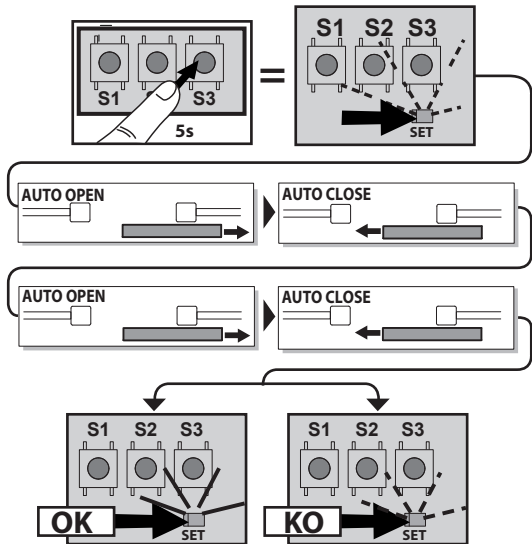

**LEGENDA - KEY - LÉGENDE
LEGENDE - LEYENDA - LEGENDA**

Fisso
Steadily lit
Fixe
Ununterbrochen an
Fijo
Continu



Lampeggio continuo
Continuous flashing
Clignotement continu
Kontinuierliches Blinken
Parpadeo continuo
Continu knipperen



Lampeggio intermittente
Intermittent flashing
Clignotement intermittent
intermittierendes Blinken
Parpadeo intermitente
Met intervallen knipperen



1

J

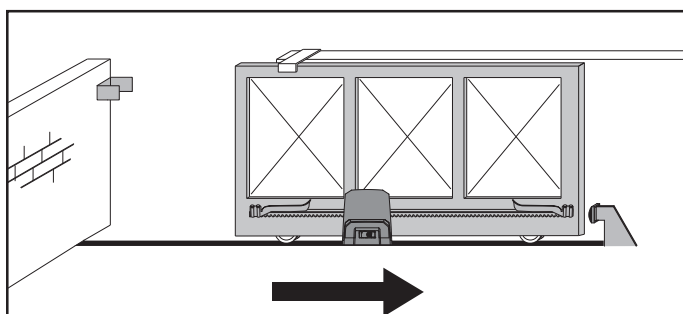

verso di apertura: destra
opening direction: right
sens de l'ouverture : droite
Öffnungsrichtung: rechts
sentido de apertura: derecha
openingsrichting: rechtsverso

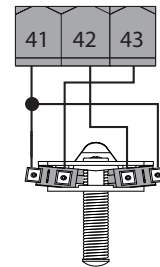
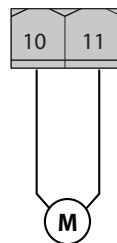

2

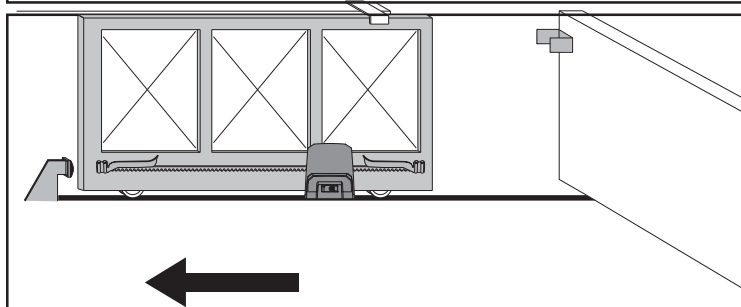

verso di apertura: sinistra
opening direction: left
sens de l'ouverture : gauche
Öffnungsrichtung: links
sentido de apertura: izquierda
openingsrichting: links

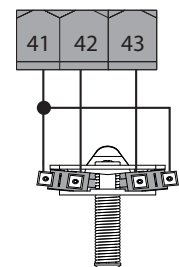
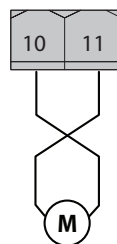

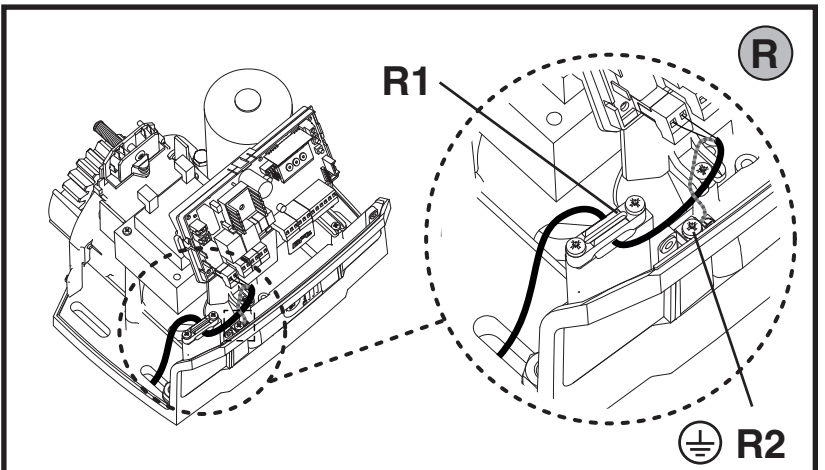
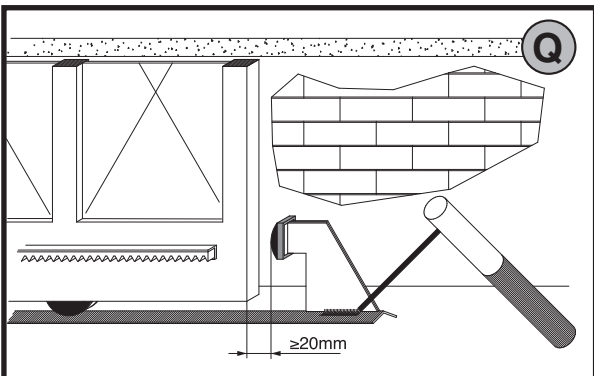
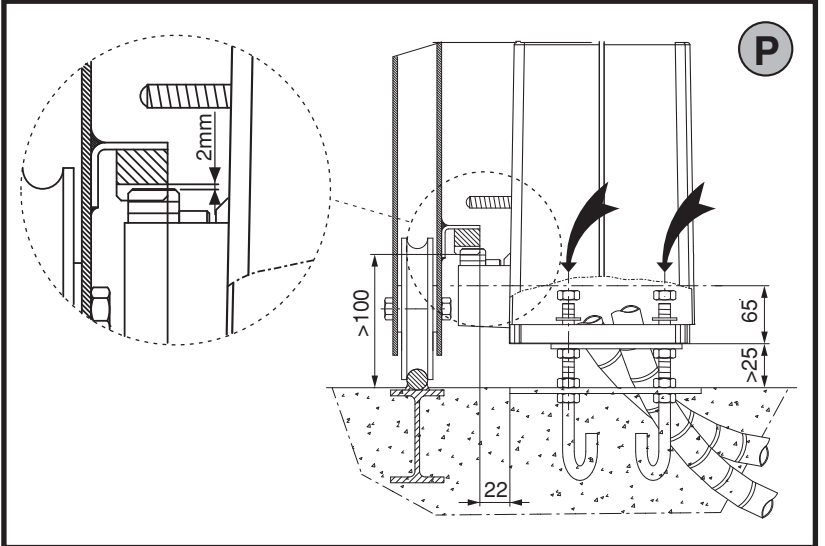
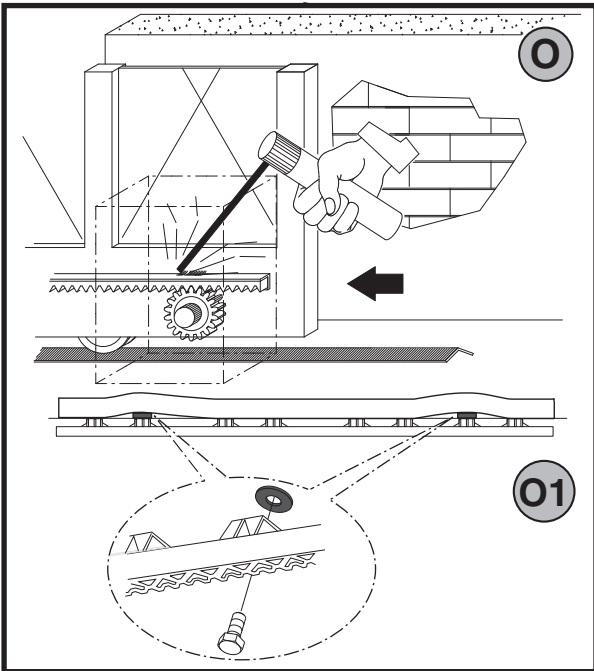
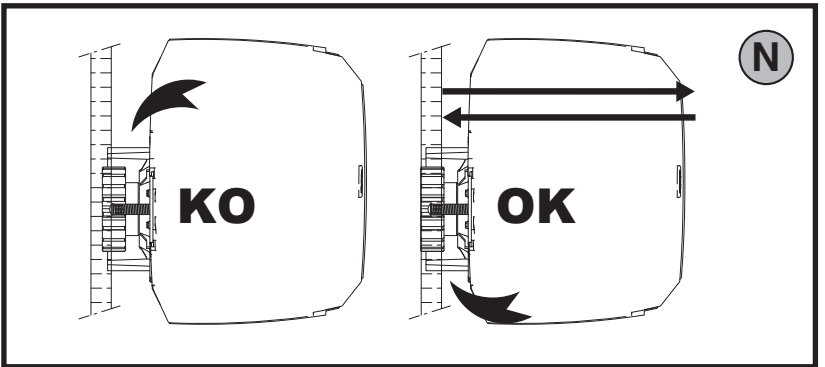
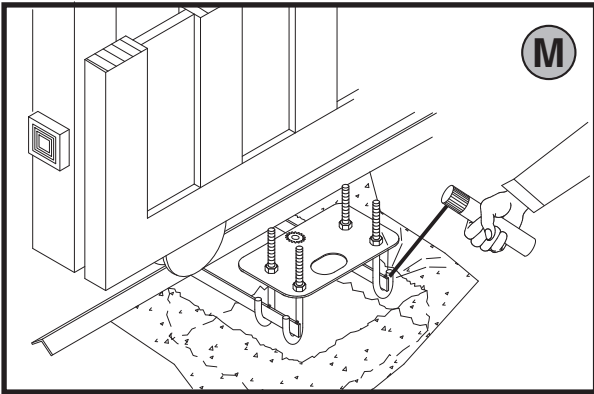
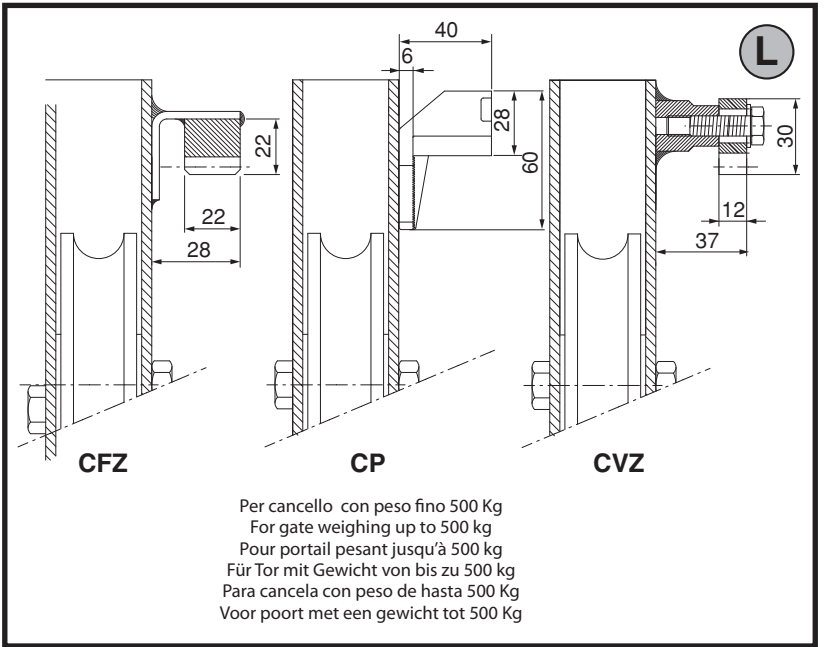
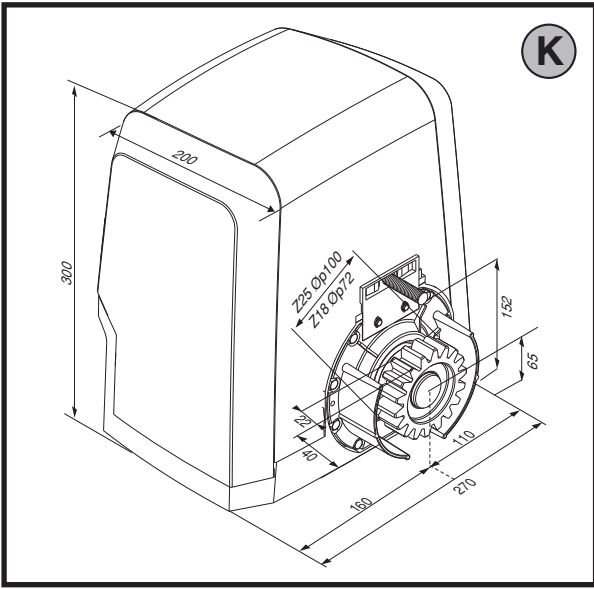

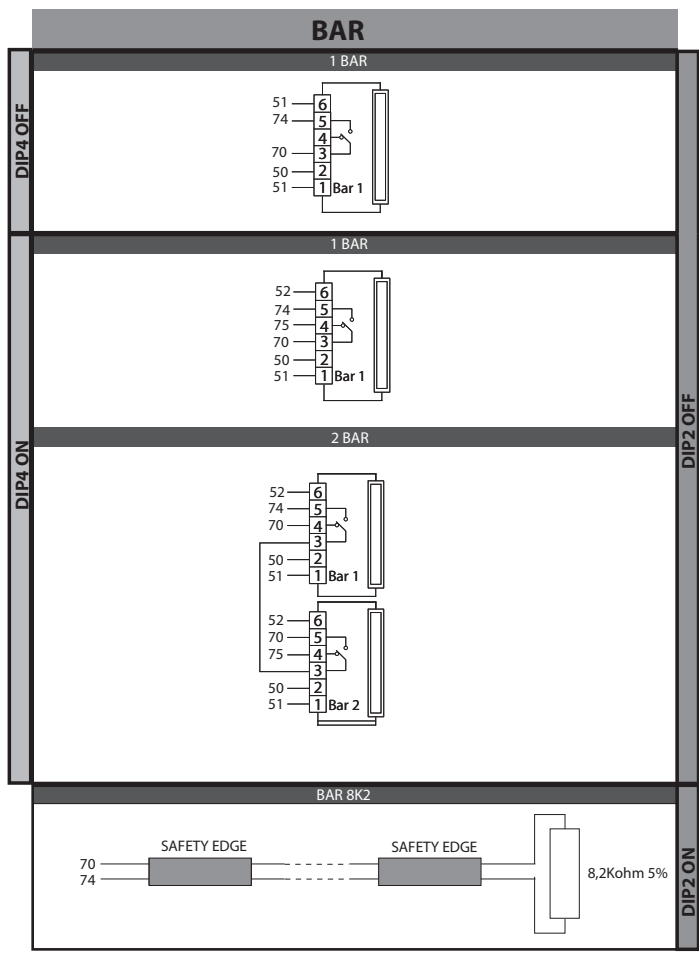
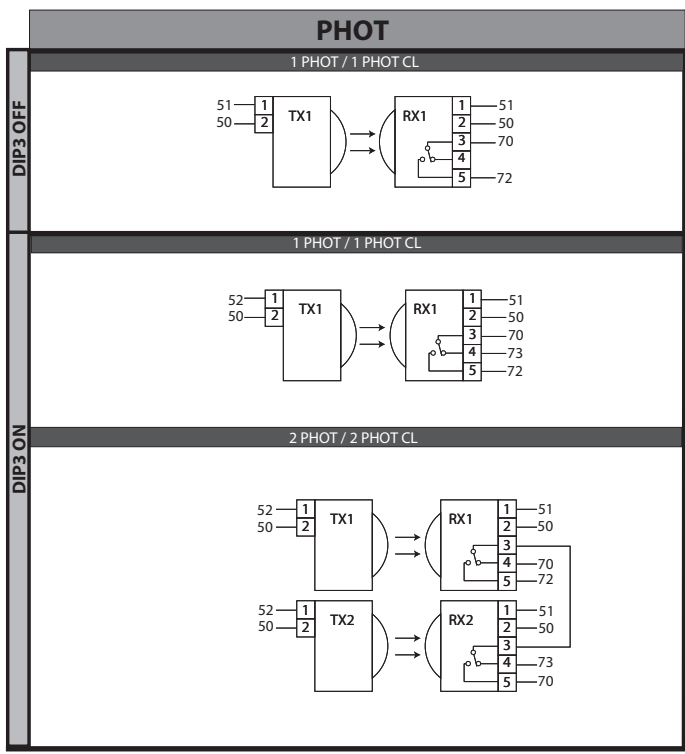
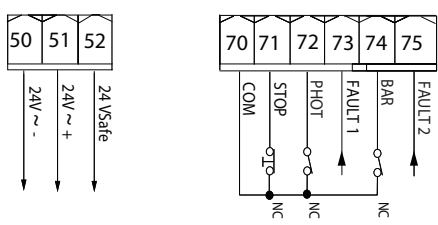

Regolazione velocità massima e spazio rallentamento con trimmer T3 - Maximum speed and slowdown space adjustment with T3 trimmer
 Réglage de la vitesse maximum et distance de ralentissement avec déclencheur T3 - Einstellung max. geschwindigkeit und Verlangsamungsraum mit Trimmer T3
 Regulación velocidad máxima y espacio deceleración con trimmer T3. - Regeling maximum snelheid en ruimte afremming met trimmer T3

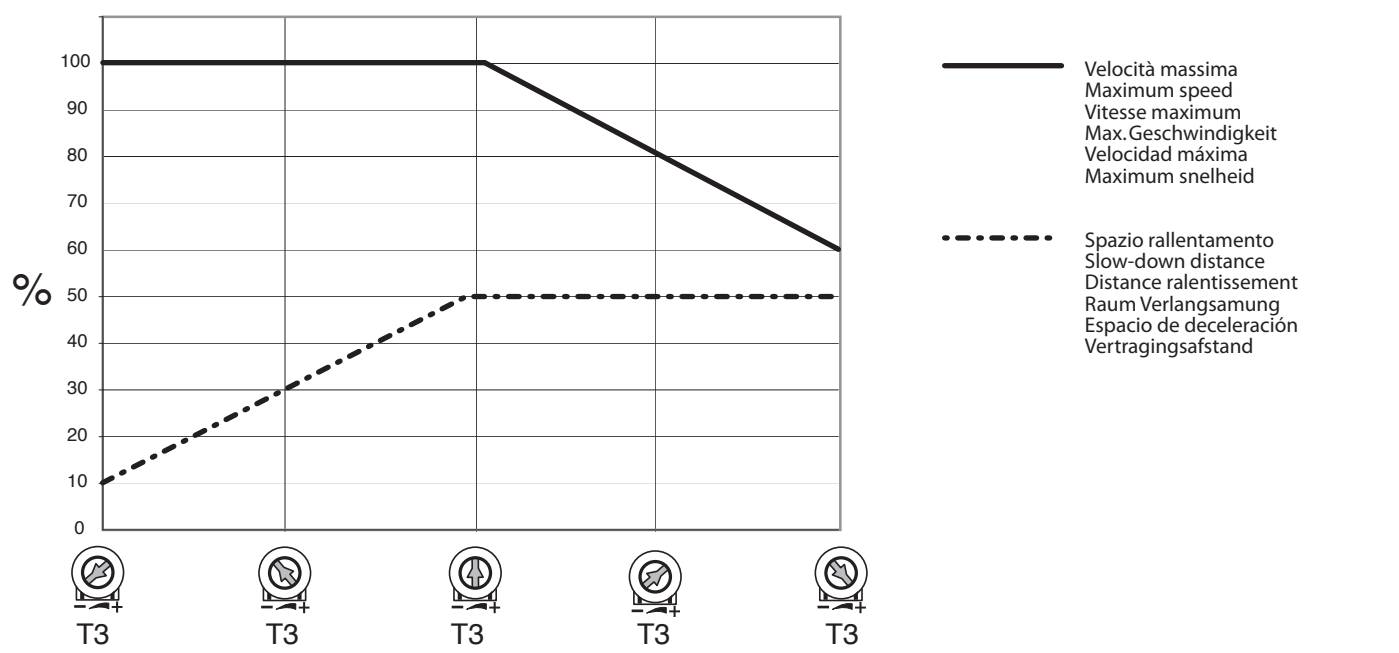

INSTALLER WARNINGS

WARNING! Important safety instructions. Carefully read and comply with all the warnings and instructions that come with the product as incorrect installation can cause injury to people and animals and damage to property. The warnings and instructions give important information regarding safety, installation, use and maintenance. Keep hold of instructions so that you can attach them to the technical file and keep them handy for future reference.

GENERAL SAFETY

This product has been designed and built solely for the purpose indicated herein. Uses other than those indicated herein might cause damage to the product and create a hazard.

- The units making up the machine and its installation must meet the requirements of the following European Directives, where applicable: 2004/108/EC, 2006/95/EC, 2006/42/EC, 89/106/EC, 99/05/EC and later amendments. For all countries outside the EEC, it is advisable to comply with the standards mentioned, in addition to any national standards in force, to achieve a good level of safety.
- The Manufacturer of this product (hereinafter referred to as the "Firm") disclaims all responsibility resulting from improper use or any use other than that for which the product has been designed, as indicated herein, as well as for failure to apply Good Practice in the construction of entry systems (doors, gates, etc.) and for deformation that could occur during use.
- Installation must be carried out by qualified personnel (professional installer, according to EN 12635), in compliance with Good Practice and current code.
- Before installing the product, make all structural changes required to produce safety gaps and to provide protection from or isolate all crushing, shearing and dragging hazard areas and danger zones in general in accordance with the provisions of standards EN 12604 and 12453 or any local installation standards. Check that the existing structure meets the necessary strength and stability requirements.
- Before commencing installation, check the product for damage.
- The Firm is not responsible for failure to apply Good Practice in the construction and maintenance of the doors, gates, etc. to be motorized, or for deformation that might occur during use.
- Make sure the stated temperature range is compatible with the site in which the automated system is due to be installed.
- Do not install this product in an explosive atmosphere: the presence of flammable fumes or gas constitutes a serious safety hazard.
- Disconnect the electricity supply before performing any work on the system. Also disconnect buffer batteries, if any are connected.
- Before connecting the power supply, make sure the product's ratings match the mains ratings and that a suitable residual current circuit breaker and overcurrent protection device have been installed upline from the electrical system. Have the automated system's mains power supply fitted with a switch or omnipolar thermal-magnetic circuit breaker with a contact separation that provide full disconnection under overvoltage category III conditions.
- Make sure that upline from the mains power supply there is a residual current circuit breaker that trips at no more than 0.03A as well as any other equipment required by code.
- Make sure the earth system has been installed correctly: earth all the metal parts belonging to the entry system (doors, gates, etc.) and all parts of the system featuring an earth terminal.
- Installation must be carried out using safety devices and controls that meet standards EN 12978 and EN 12453.
- Impact forces can be reduced by using deformable edges.
- In the event impact forces exceed the values laid down by the relevant standards, apply electro-sensitive or pressure-sensitive devices.
- Apply all safety devices (photocells, safety edges, etc.) required to keep the area free of impact, crushing, dragging and shearing hazards. Bear in mind the standards and directives in force, Good Practice criteria, intended use, the installation environment, the operating logic of the system and forces generated by the automated system.
- Apply all signs required by current code to identify hazardous areas (residual risks). All installations must be visibly identified in compliance with the provisions of standard EN 13241-1.
- Once installation is complete, apply a nameplate featuring the door/gate's data.
- This product cannot be installed on leaves incorporating doors (unless the motor can be activated only when the door is closed).
- If the automated system is installed at a height of less than 2.5 m or is accessible, the electrical and mechanical parts must be suitably protected.
- For roller shutter automation only
 - 1) The motor's moving parts must be installed at a height greater than 2.5 m above the floor or other surface from which they may be reached.
 - 2) The gearmotor must be installed in a segregated and suitably protected space so that it cannot be reached without the aid of tools.
- Install any fixed controls in a position where they will not cause a hazard, away from moving parts. More specifically, hold-to-run controls must be positioned within direct sight of the part being controlled and, unless they are key operated, must be installed at a height of at least 1.5 m and in a place where they cannot be reached by the public.
- Apply at least one warning light (flashing light) in a visible position, and also attach a Warning sign to the structure.
- Attach a label near the operating device, in a permanent fashion, with information on how to operate the automated system's manual release.
- Make sure that, during operation, mechanical risks are avoided or relevant protective measures taken and, more specifically, that nothing can be banged, crushed, caught or cut between the part being operated and surrounding parts.
- Once installation is complete, make sure the motor automation settings are correct and that the safety and release systems are working properly.
- Only use original spare parts for any maintenance or repair work. The Firm disclaims all responsibility for the correct operation and safety of the automated system if parts from other manufacturers are used.
- Do not make any modifications to the automated system's components unless explicitly authorized by the Firm.
- Instruct the system's user on what residual risks may be encountered, on the control systems that have been applied and on how to open the system manually in an emergency. Give the user guide to the end user.

-Dispose of packaging materials (plastic, cardboard, polystyrene, etc.) in accordance with the provisions of the laws in force. Keep nylon bags and polystyrene out of reach of children.

WIRING

WARNING! For connection to the mains power supply, use a multicore cable with a cross-sectional area of at least 5x1.5mm² or 4x1.5mm² when dealing with three-phase power supplies or 3x1.5mm² for single-phase supplies (by way of example, type H05 VV-F cable can be used with a cross-sectional area of 4x1.5mm²). To connect auxiliary equipment, use wires with a cross-sectional area of at least 0.5 mm².

- Only use pushbuttons with a capacity of 10A-250V or more.
- Wires must be secured with additional fastening near the terminals (for example, using cable clamps) in order to keep live parts well separated from safety extra low voltage parts.
- During installation, the power cable must be stripped to allow the earth wire to be connected to the relevant terminal, while leaving the live wires as short as possible. The earth wire must be the last to be pulled taut in the event the cable's fastening device comes loose.

WARNING! safety extra low voltage wires must be kept physically separate from low voltage wires.

Only qualified personnel (professional installer) should be allowed to access live parts.

CHECKING THE AUTOMATED SYSTEM AND MAINTENANCE

Before the automated system is finally put into operation, and during maintenance work, perform the following checks meticulously:

- Make sure all components are fastened securely.
- Check starting and stopping operations in the case of manual control.
- Check the logic for normal or personalized operation.
- For sliding gates only: check that the rack and pinion mesh correctly with 2 mm of play along the full length of the rack; keep the track the gate slides on clean and free of debris at all times.
- For sliding gates and doors only: make sure the gate's running track is straight and horizontal and that the wheels are strong enough to take the weight of the gate.
- For cantilever sliding gates only: make sure there is no dipping or swinging during operation.
- For swing gates only: make sure the leaves' axis of rotation is perfectly vertical.
- For barriers only: before opening the door, the spring must be decompressed (vertical boom).
- Check that all safety devices (photocells, safety edges, etc.) are working properly and that the anti-crush safety device is set correctly, making sure that the force of impact measured at the points provided for by standard EN 12445 is lower than the value laid down by standard EN 12453.
- Impact forces can be reduced by using deformable edges.
- Make sure that the emergency operation works, where this feature is provided.
- Check opening and closing operations with the control devices applied.
- Check that electrical connections and cabling are intact, making extra sure that insulating sheaths and cable glands are undamaged.
- While performing maintenance, clean the photocells' optics.
- When the automated system is out of service for any length of time, activate the emergency release (see "EMERGENCY OPERATION" section) so that the operated part is made idle, thus allowing the gate to be opened and closed manually.
- If the power cord is damaged, it must be replaced by the manufacturer or their technical assistance department or other such qualified person to avoid any risk.
- If "D" type devices are installed (as defined by EN12453), connect in unverified mode, foresee mandatory maintenance at least every six months
- The maintenance described above must be repeated at least once yearly or at shorter intervals where site or installation conditions make this necessary.

WARNING!

Remember that the drive is designed to make the gate/door easier to use and will not solve problems as a result of defective or poorly performed installation or lack of maintenance



SCRAPPING

Materials must be disposed of in accordance with the regulations in force. Do not throw away your discarded equipment or used batteries with household waste. You are responsible for taking all your waste electrical and electronic equipment to a suitable recycling centre.

DISMANTLING

If the automated system is being dismantled in order to be reassembled at another site, you are required to:

- Cut off the power and disconnect the whole electrical system.
- Remove the actuator from the base it is mounted on.
- Remove all the installation's components.
- See to the replacement of any components that cannot be removed or happen to be damaged.

**DECLARATIONS OF CONFORMITY CAN BE FOUND AT <http://www.bft-automation.com/CE>
INSTRUCTIONS FOR USE AND ASSEMBLY CAN BE FOUND IN THE DOWN-LOAD SECTION.**

Anything that is not explicitly provided for in the installation manual is not allowed. The operator's proper operation can only be guaranteed if the information given is complied with. The Firm shall not be answerable for damage caused by failure to comply with the instructions featured herein.

While we will not alter the product's essential features, the Firm reserves the right, at any time, to make those changes deemed opportune to improve the product from a technical, design or commercial point of view, and will not be required to update this publication accordingly.

1) GENERAL INFORMATION

The **ARES BT A** actuator is highly versatile in terms of installation options due to the extremely low position of the pinion, the actuator's compact nature and the height and depth adjustment features it offers. The adjustable electronic torque limiter provides anti-crush safety. Manual emergency operation is extremely easy to perform using just a release lever.

Stopping at end of travel is controlled by electromechanical microswitches.

The **HAMAL** control panel comes with standard factory settings.

Any change must be set by means of the TRIMMER and DIP SWITCH settings.

Its main features are:

- Control of 1 low-voltage motor
 - Obstacle detection
 - Separate inputs for safety devices
 - Built-in radio receiver rolling code with transmitter cloning.
- The board has a terminal strip of the removable kind to make maintenance or replacement easier. It comes with a series of prewired jumpers to make the installer's job on site easier. The jumpers concern terminals: 70-71, 70-72, 70-74. If the above-mentioned terminals are being used, remove the relevant jumpers.

TESTING

The **HAMAL** panel controls (checks) the start relays and safety devices (photocells) before performing each opening and closing cycle.

If there is a malfunction, make sure that the connected devices are working properly and check the wiring.

2) TECHNICAL SPECIFICATIONS

MOTOR		
	1000	1500
Power supply	110-120V 50/60Hz 220-230V 50/60 Hz(*)	
Power input	240 W	400 W
Pinion module ARES	4mm (18 teeth)	4mm (18 teeth)
Pinion module ARES V	4mm (25 teeth)	4mm (25 teeth)
Leaf speed ARES	9 m/min	9 m/min
Leaf speed ARES V	12 m/min	12 m/min
Max. leaf weight ARES	1000 Kg	1500 Kg
Max. leaf weight ARES V	500 Kg	750 Kg
Max. torque	30 Nm	35 Nm
Impact reaction	Electronic torque limiter	
Lubrication	Lifetime greased	
Manual operation	Lever-operated mechanical release	
Type of use	intensive	
Buffer batteries (optional extras)	Two 12V 1.2Ah batteries	
Environmental conditions	-20 / +55°C	
Protection rating	IP24	
Noise level	<70dBA	
Operator weight	7 kg	
Dimensions	See Fig. K	

CONTROL UNIT	
Low voltage/mains insulation	> 2MΩ 500V ---
Operating temperature range	-20 / +55°C
Thermal overload protection	Software
Dielectric rigidity	mains/LV 3750V~ for 1 minute
Accessories power supply	24V ~ (demand max. 0,2A) 24V ~ safe
AUX 0 - BLINKER	NO 24V ~ powered contact (max.1A)
Fuses	Fig. G
Built-in Rolling-Code radio-receiver	frequency 433.92MHz
Setting of parameters and logics	TRIMMER + DIP SWITCH
N° of combinations	4 billion
Max. n° of remotes that can be memorized	63

(*) Special supply voltages to order.

Usable transmitter versions:

All ROLLING CODE transmitters compatible with  ((ER-Ready))

3) TUBE ARRANGEMENT Fig.A

Install the electrical system referring to the standards in force for electrical systems CEI 64-8, IEC 364, harmonization document HD 384 and other national standards.

4) PREPARATION FOR MOTOR MOUNTING FIG.B

Make a hole in the ground to accommodate the concrete pad where the tie rods will be positioned, keeping to the distances featured in (FIG.B).

5) REMOVING THE COVER FIG.C

5.1) MOUNTING THE MOTOR FIG. C1

6) MOUNTING DRIVE ACCESSORIES FIG. D-D1

Recommended rack types (FIG.L)

7) RACK CENTRING WITH RESPECT TO PINION FIG. N-O1-P

 **DANGER - Welding must be performed by a competent person issued with the necessary personal protective equipment as prescribed by the safety rules in force FIG.L.**

8) FASTENING LIMIT SWITCH BRACKETS FIG. E

9) STOPS FIG. Q

 **DANGER - The gate must be fitted with mechanical stops to halt its travel both when opening and closing, thus preventing the gate from coming off the top guide. Said stops must be fastened firmly to the ground, a few centimetres beyond the electric stop point.**

10) MANUAL RELEASE (See USER GUIDE -FIG.3-).

Warning Do not JERK the gate open and closed, instead push it GENTLY to the end of its travel.

11) TERMINAL BOARD WIRING Fig. G-R

Once suitable electric cables have been run through the raceways and the automated device's various components have been fastened at the predetermined points, the next step is to connect them as directed and illustrated in the diagrams contained in the relevant instruction manuals. Connect the live, neutral and earth wire (compulsory). The mains cable must be clamped in the relevant cable gland (FIG.R-ref.R1), while the earth wire with the yellow/green-coloured sheath must be connected in the relevant terminal (FIG.R-ref.R2).

WARNINGS - When performing wiring and installation, refer to the standards in force and, whatever the case, apply good practice principles. Wires carrying different voltages must be kept physically separate from each other, or they must be suitably insulated with at least 1mm of additional insulation. Wires must be secured with additional fastening near the terminals, using devices such as cable clamps. All connecting cables must be kept far enough away from dissipaters.

	Terminal	Definition	Description
Power supply	L	LINE	Single-phase power supply
	N	NEUTRAL	
	JP31	TRANSF PRIM	Transformer primary winding connection
	JP32		
	JP13	TRANSF SEC	Board power supply: 24V~ Transformer secondary winding
Motor	10	MOT +	Connection motor 1
	11	MOT -	
Aux	20	AUX 0 -BLINKER 24V (N.O.) (MAX. 1A)	Contact stays closed while leaf is operating.
	21		
Limit switches	41	+REF SWE	Limit switch common
	42	SWC	Closing limit switch SWC (N.C.)
	43	SWO	Opening limit switch SWO (N.C.)
Accessories power supply	50	24V~ (-)	Accessories power supply output.
	51	24V~ (+)	
	52	24 Vsafe	Tested safety device power supply output (photozell transmitter and safety edge transmitter). Output active only during operating cycle.
Commands	60	Common	START and OPEN inputs common
	61	START	START command button (N.O.). Operation according to "3/4-STEP" logic
	62	OPEN	OPEN command button (N.O.). Gate opened with this command. If the input stays closed, the leaves stay open until the contact is opened. When the contact is open, the automated device closes following the TCA time, where activated.
Safety devices	70	Common	STOP, PHOT and BAR inputs common
	71	STOP	The command stops movement. (N.C.) If not used, leave jumper inserted.
	72	PHOT (*)	PHOTOCELL input (N.C.). Operation according to "PHOTOCELL/PHOTOCELL DURING CLOSING" logic. If not used, leave jumper inserted.
	73	FAULT 1	Test input for safety devices connected to PHOT.
	74	BAR (*)	BAR safety edge input (N.C.). Configurable according to the "BAR/ 8K2" logic. The command reverses movement for 2 sec. If not used, leave jumper inserted.
	75	FAULT 2	Test input for safety devices connected to BAR.
Antenna	Y	ANTENNA	Antenna input. Use an antenna tuned to 433MHz. Use RG58 coax cable to connect the Antenna and Receiver. Metal bodies close to the antenna can interfere with radio reception. If the transmitter's range is limited, move the antenna to a more suitable position.
	#	SHIELD	

11.1) LOCAL COMMANDS Fig. G

Pressing the S3 key commands one START. By pressing the key again while the automated device is moving a STOP is commanded.

12) SAFETY DEVICES

Note: only use receiving safety devices with free changeover contact.

12.1) TESTED DEVICES Fig.S

12.2) CONNECTION OF 1 PAIR OF NON-TESTED PHOTOCELLS FIG. H

13) MEMORIZING TRANSMITTERS FIG. I

RADIO

IMPORTANT NOTE: THE FIRST TRANSMITTER MEMORIZED MUST BE IDENTIFIED BY ATTACHING THE KEY LABEL (MASTER).

In the event of manual programming, the first transmitter assigns the RECEIVER'S KEY CODE: this code is required to subsequently clone the radio transmitters. The Clonix built-in on-board receiver also has a number of important advanced features:

- Cloning of master transmitter (rolling code or fixed code).
- Cloning to replace transmitters already entered in receiver.
- Transmitter database management.
- Receiver community management.

To use these advanced features, refer to the universal handheld programmer's instructions and to the general receiver programming guide.

14) AUTOSSET ADJUSTMENT FIG. I1

Enables Motor Torque to be set automatically.

If the power is suddenly disconnected and then restored the automation performs the operations at autoset speed till the travel limits are identified.

WARNING!! The autoset operation must be performed only once you have checked that the leaf is moving accurately (opening/closing) and that the mechanical stops are positioned correctly.

An autoset cycle must be run whenever the slow-down distance is modified (T3).

WARNING! While the autoset function is running, the obstacle detection function is not active. Consequently, the installer must monitor the automated device's movements and keep people and property out of range of the automated device.

WARNING: check that the force of impact measured at the points provided for by standard EN 12445 is lower than the value laid down by standard EN 12453. Setting sensitivity incorrectly can result in damage to property and injury to

people and animals.

15) REVERSING THE OPENING DIRECTION (Fig.J)

KEYS

KEYS	Description
S1	Add Start Key associates the desired key with the Start command.
S2	Add Pedestrian Key associates the desired key with the pedestrian command.
S2 >5s	Confirms the changes made to parameter settings and operating
S1+S2 >10s	Erase List  WARNING! Erases all memorized transmitters from the receiver's memory.
S3	Pressed BRIEFLY, it gives the START command.
	HELD DOWN (>5 sec.), it activates the AUTOSSET function.

TABLE "A" - PARAMETERS

Any modification of parameters/logics must be confirmed by pressing S2 > 5s

TRIMMER	Parameter			Description
		min.	max.	
T1	Automatic closing time [s]	0	120	Waiting time before automatic closing. NOTE: Set to 0 if not used.
T2	Leaf force [%]	10	90	Force exerted by leaf/leaves. This is the percentage of force delivered, beyond the force stored during the autosec cycle (and subsequently updated), before an obstacle alarm is generated. WARNING: It affects impact force directly: make sure that current safety requirements are met with the set value (*). Install anti-crush safety devices where necessary.
T3	Slow-down distance [%]	10	50	Set the opening and closing slowdown speed as a percentage of total travel. This distance is travelled at low speed. Set also the movement maximum speed while opening and closing. Note: when this parameter is modified, a new Autosec must be performed to confirm it. The graph in fig. T shows the variation of the two parameters according to the trimmer rotation
	Maximum speed [%]	99	60	

(*) In the European Union, apply standard EN 12453 for force limitations, and standard EN 12445 for measuring method.

TABLE "B" - LOGICS

Any modification of parameters/logics must be confirmed by pressing S2 > 5s

DIP	Logic	Default	Cross out setting used	Description
1	Transmitter programming	ON	ON	Enables wireless memorizing of transmitters: 1- Press in sequence the hidden key and normal key (T1-T2-T3-T4) of a transmitter that has already been memorized in standard mode via the radio menu. 2- Press within 10 sec. the hidden key and normal key (T1-T2-T3-T4) of a transmitter to be memorized. The receiver exits programming mode after 10 sec.: you can use this time to enter other new transmitters. This mode does not require access to the control panel. IMPORTANT: Enables the automatic addition of new transmitters, clones and replays.
			OFF	Disables wireless memorizing of transmitters and automatic addition of clones. Transmitters are memorized only using the relevant Radio menu or automatically with replays. IMPORTANT: Disables the automatic addition of new transmitters and clones
2	BAR / 8K2	OFF	ON	Input configured as Bar 8k2. Input for resistive edge 8K2. The command reverses movement for 2 sec.
			OFF	Input configured as Bar, safety edge. The command reverses movement for 2 sec.
3	Photocell input check	OFF	ON	Enable safety check on the PHOT input
			OFF	Safety check on PHOT input not enabled
4	Edge input check	OFF	ON	Enable safety check on the BAR input
			OFF	Safety check on BAR input not enabled
5	Photocells during closing	OFF	ON	In the event beam is broken, photocell operation is disabled during opening. During closing, movement is reversed immediately.
			OFF	When beam is broken, photocells are active during both opening and closing. When beam is broken during closing, movement is reversed only once the photocell is cleared.
6	Fast closing	OFF	ON	Closes 3 seconds after the photocells are cleared before waiting for the set TCA to elapse.
			OFF	Logic not enabled
7	Block pulses during opening	OFF	ON	The start pulse has no effect during opening.
			OFF	The start pulse has effect during opening.
8	3-step logic	OFF	ON	Switches to 3-step logic; during closing, start reverses movement.
			OFF	Switches to 4-step logic.

	3 step	4 step
CLOSED	opens	opens
DURING CLOSING		stop
OPEN	closes	closes
DURING OPENING	stop + TCA	stop + TCA
AFTER STOP	opens	opens

D81220000100_03

ENGLISH

LED INDICATORS:

POWER	Steadily lit: - Mains power on - Board powered - Fuse F1 intact
START	Lit: START input activated
OPEN	Lit: OPEN pedestrian input activated
STOP	Unlit: STOP input activated
PHOT	Unlit: PHOT photocell input activated
FAULT 1	PHOT input safety device test input diagnostics
BAR	Unlit: BAR safety edge input activated
FAULT 2	BAR input safety device test input diagnostics
SWC	Unlit: leaf fully closed
	Lit: motor limit switch is disengaged
SWO	Unlit: leaf fully open
	Lit: motor limit switch is disengaged
ERR	Unlit: no error
	LIT: see error diagnostics table
RADIO (GREEN)	Unlit: remote programming not active
	Radio LED only flashing: Remote programming active, waiting for hidden key.
	Flashing in sync with Set LED: Transmitter deletion in progress
	Lit: remote programming active, waiting for desired key.
SET	Lit 1s: Radio receiver channel activated
	Lit: Set key pressed / Autoset completed successfully
	Flashes three times: Autoset in progress
	Fast flashing 10s: Autoset failed
	Flashing in sync with Radio LED: Transmitter deletion in progress
	Lit 1s: Start/Stop after key S3 pressed
Lit 10s: Autoset completed correctly	

16) ADJUSTMENT PROCEDURE

- Before turning the unit on, check electrical connections.
- Set the following parameters: Automatic Closing Time, motor force, slow-down distance.
- Set the logics.
- Run the autoset function.

WARNING! Incorrect settings can result in damage to property and injury to people and animals.

! WARNING: Check that the force of impact measured at the points provided for by standard EN 12445 is lower than the value laid down by standard EN 12453.

For best results, it is advisable to run the autoset function with the motors idle (i.e. not overheated by a considerable number of consecutive operations)

17) INSTALLATION TEST PROCEDURE

1. Run the AUTOSET cycle (*)
 2. Check the impact forces: if they fall within the limits (**) skip to point 9 of the procedure, otherwise
 3. Where necessary, adjust the sensitivity (force) parameter: see parameters table.
 4. Check the impact forces again: if they fall within the limits (**) skip to point 9 of the procedure, otherwise
 5. Apply a shock absorber profile
 6. Check the impact forces again: if they fall within the limits (**) skip to point 9 of the procedure, otherwise
 7. Apply pressure-sensitive or electro-sensitive protective devices (such as a safety edge)
 8. Check the impact forces again: if they fall within the limits (**) skip to point 9 of the procedure, otherwise
 9. Make sure all devices designed to detect obstacles within the system's operating range are working properly
- (*) Before running the autoset function, make sure you have performed all the assembly and make-safe operations correctly, as set out in the installation warnings in the drive's manual.
- (**) Based on the risk analysis, you may find it necessary to apply sensitive protective devices anyway

WARNING! Incorrect settings can result in damage to property and injury to people and animals.

LED ERR:

Led SET	Led ERR		
	Lit	slow flashing	fast flashing
Unlit:	<u>Reverse due to obstacle - Amperostop</u> - Check for obstacles in path	<u>Photocell test, Costa o Costa 8k2 failed</u> - Check photocell connection and/or logic settings	<u>Thermal cutout</u> - Allow automated device to cool
Lit	<u>Internal system supervision control error.</u> - Try switching the board off and back on again. If the problem persists, contact the technical assistance department.		<u>Limit switch error</u> - Check limit switch connections
slow flashing	<u>Photocell test failed</u> - Check photocell connection and/or logic settings		<u>Parameters and/or Operating Logic edited</u> - If the "Slow-down distance" is edited, run a new Autoset cycle to confirm the new setting. - If other parameters and/or operating logic are edited, hold down S2 for 5s to confirm. NOTE: In any case, the Autoset function confirms all changes made to the board.

FIG. 3

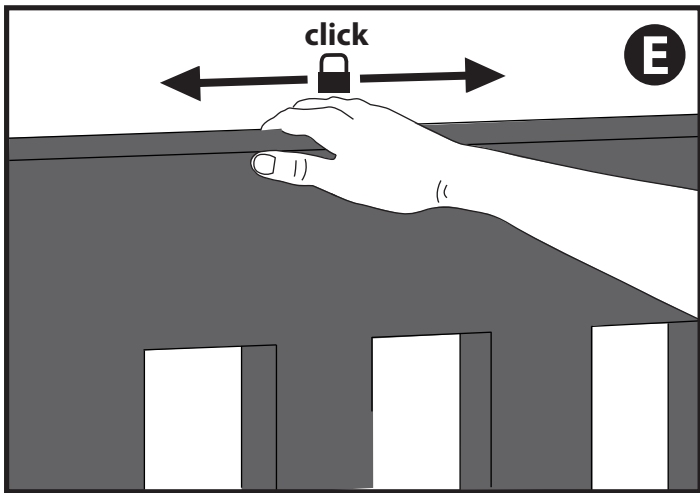
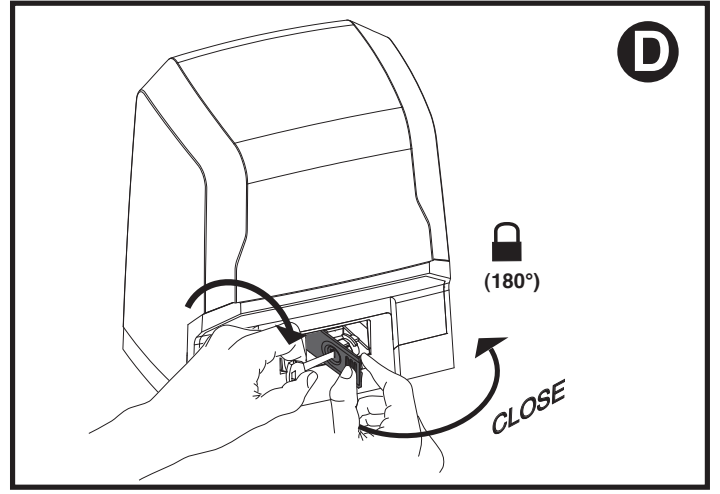
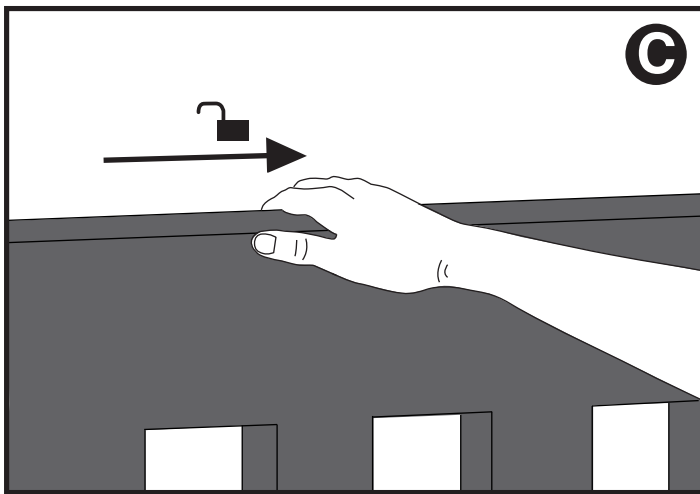
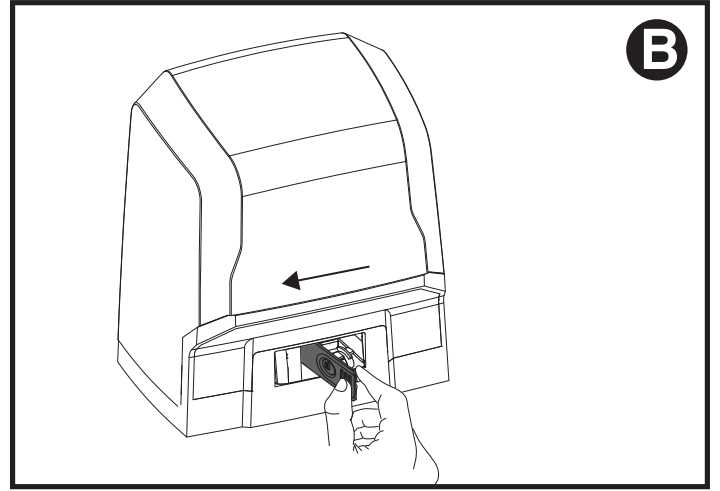
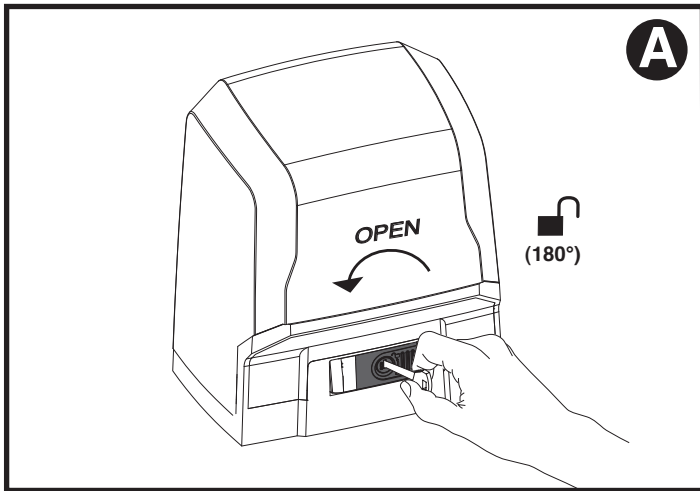

Bft Spa

Via Lago di Vico, 44
36015 Schio (VI)
T +39 0445 69 65 11
F +39 0445 69 65 22
→ www.bft.it

**SPAIN**

BFT GROUP ITALIBERICA DE AUTOMATISMOS S.L.
08401 Granollers - (Barcelona)
www.bftautomatismos.com

FRANCE

AUTOMATISMES BFT FRANCE
69800 Saint Priest
www.bft-france.com

GERMANY

BFT TORANTRIEBSSYSTEME GmbH
90522 Oberasbach
www.bft-torantriebe.de

UNITED KINGDOM

BFT AUTOMATION UK LTD
Stockport, Cheshire, SK7 5DA
www.bft.co.uk

IRELAND

BFT AUTOMATION LTD
Dublin 12

BENELUX

BFT BENELUX SA
1400 Nivelles
www.bftbenelux.be

POLAND

BFT POLSKA SP. Z O.O.
05-091 ZĄBKI
www.bft.pl

CROATIA

BFT ADRIA D.O.O.
51218 Drazice (Rijeka)
www.bft.hr

PORTUGAL

BFT SA-COMERCIO DE AUTOMATISMOS E MATERIAL DE SEGURANCIA
3020-305 Coimbra
www.bftportugal.com

CZECH REPUBLIC

BFT CZ S.R.O.
Praha
www.bft.it

TURKEY

BFT OTOMATIK KAPI SISTEMELERI SANAY VE
Istanbul
www.bftotomasyon.com.tr

RUSSIA

BFT RUSSIA
111020 Moscow
www.bftprus.ru

AUSTRALIA

BFT AUTOMATION AUSTRALIA PTY LTD
Wetherill Park (Sydney)
www.bftaustralia.com.au

U.S.A.

BFT USA
Boca Raton
www.bft-usa.com

CHINA

BFT CHINA
Shanghai 200072
www.bft-china.cn

UAE

BFT Middle East FZCO
Dubai