

- I** QUADRO COMANDO
- GB** CONTROL PANEL
- F** CENTRALE DE COMMANDE
- D** STEUERPLATINE
- E** CUADRO DE MANDOS
- P** QUADRO DE COMANDO

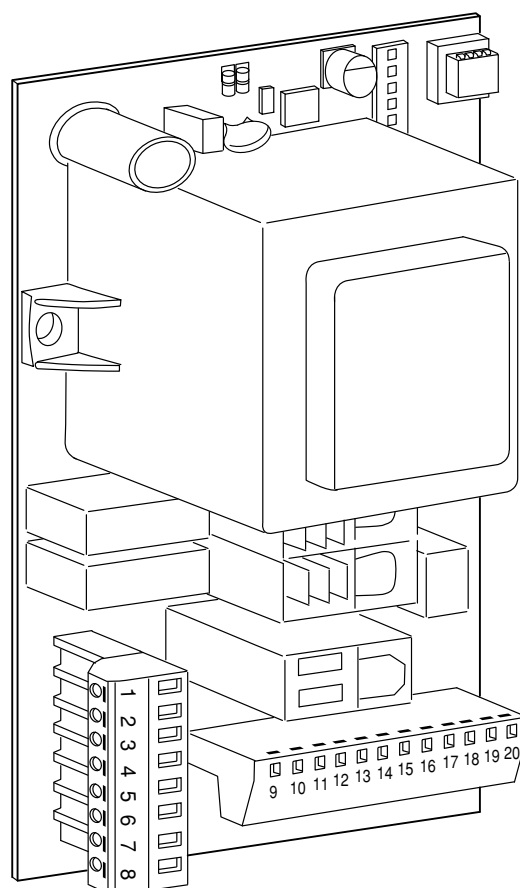

# ALCOR N

**ISTRUZIONI D'USO E DI INSTALLAZIONE**  
**INSTALLATION AND USER'S MANUAL**  
**INSTRUCTIONS D'UTILISATION ET D'INSTALLATION**  
**MONTAGE- und BEDIENUNGSANLEITUNG**  
**INSTRUCCIONES DE USO Y DE INSTALACION**  
**INSTRUÇÕES DE USO E DE INSTALAÇÃO**



**AZIENDA CON SISTEMA  
 DI GESTIONE INTEGRATO  
 CERTIFICATO DA DNV  
 = UNI EN ISO 9001:2000 =  
 UNI EN ISO 14001:1996**

Via Lago di Vico, 44  
 36015 Schio (VI)  
 Tel.naz. 0445 696511  
 Tel.int. +39 0445 696533  
 Fax 0445 696522  
 Internet: [www.bft.it](http://www.bft.it)  
 E-mail: [sales@bft.it](mailto:sales@bft.it)

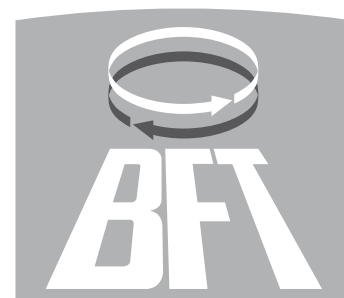

**DICHIARAZIONE DI CONFORMITÀ / DECLARATION OF CONFORMITY / DÉCLARATION DE CONFORMITÉ  
KONFORMITÄTSERKLÄRUNG / DECLARACION DE CONFORMIDAD / DECLARAÇÃO DE CONFORMIDADE**

Fabbricante / Manufacturer / Fabricant / Hersteller / Fabricante / Fabricante:

BFT S.p.a.

Indirizzo / Address / Adresse / Adresse / Dirección / Endereço:

Via Lago di Vico 44  
36015 - Schio  
VICENZA - ITALY

- Dichiaro sotto la propria responsabilità che il prodotto: / Declares under its own responsibility that the following product:  
/Déclare sous sa propre responsabilité que le produit: / Erklärt auf eigene Verantwortung, daß das Produkt: / Declara, bajo su propia responsabilidad, que el producto: / Declara, sob a sua responsabilidade, que o produto:

Centralina di comando mod./ Control unit mod./ Unité de commande mod./ Steuerzentrale mod./ Central de mando mod./ Central do mando mod./

**ALCOR N**

- È conforme ai requisiti essenziali di sicurezza delle Direttive: / It complies with the main safety requirements of the following Directives: / Est conforme aux exigences essentielles de sécurité des Directives: / Es entspricht den grundlegenden Sicherheitsbedingungen der Direktiven: / Es conforme a los requisitos esenciales de seguridad de las Directivas: / Está conforme aos requisitos essenciais de segurança das Directivas:

BASSA TENSIONE / LOW VOLTAGE / BASSE TENSION / NIEDERSpannung / BAJA TENSION / BAIXA TENSÃO 73/23/CEE, 93/68/CEE (EN60335-1 ('02)+ A11(del 2004)) (e modifiche successive / and subsequent amendments / et modifications successives / und ihren nachfolgende Änderungen / e modificações sucessivas / y modificaciones sucesivas).

COMPATIBILITÀ ELETTROMAGNETICA / ELECROMAGNETIC COMPATIBILITY / COMPATIBILITÉ ÉLECTROMAGNÉTIQUE / ELEKTROMAGNETISCHE KOMPATIBILITÄT / COMPATIBILIDAD ELECTROMAGNETICA / COMPATIBILIDADE ELECTROMAGNÉTICA 89/336/CEE, 91/263/CEE, 92/31/CEE, 93/68/CEE (EN61000-6-1, EN61000-6-2, EN61000-6-3, EN61000-6-4, EN55014-1, EN55014-2) (e modifiche successive / and subsequent amendments / et modifications successives / und ihren nachfolgende Änderungen / e modificações sucessivas / y modificaciones sucesivas).

APPARECCHIATURE RADIO / RADIO SETS / INSTALLATIONS RADIO / RADIOAPPARATE / RADIOEQUIPOS / RADIOAPARELHOS 99/5/CEE (ETSI EN 301 489-3 (2000) +ETSI EN 301 489-1 (2000), ETSI EN 300 220-3 (2000)) (e modifiche successive / and subsequent amendments / et modifications successives / und ihren nachfolgende Änderungen / e modificações sucessivas / y modificaciones sucesivas).

SCHIO, 27/06/2006

Il Rappresentante Legale / The Legal Representative  
Le Représentant Légal / Der gesetzliche Vertreter  
El Representante Legal / O Representante legal

  
(GIANCARLO BONOLLO)

Nel ringraziarVi per la preferenza accordata a questo prodotto, la ditta è certa che da esso otterrete le prestazioni necessarie al Vostro uso.

Leggete attentamente l'opuscolo "Avvertenze" ed il "Libretto istruzioni" che accompagnano questo prodotto in quanto forniscono importanti indicazioni riguardanti la sicurezza, l'installazione, l'uso e la manutenzione. Questo prodotto risponde alle norme riconosciute della tecnica e della disposizioni relative alla sicurezza. Confermiamo che esso è conforme alle seguenti direttive europee: 89/336/CEE, 73/23/CEE e loro modifiche successive.

### 1) GENERALITÀ

La centralina Mod. ALCOR N è adatta per cancelli a battente. Può comandare uno o due operatori.

### 2) DEMOLIZIONE

**Attenzione: Avvalersi esclusivamente di personale qualificato.**

L'eliminazione dei materiali va fatta rispettando le norme vigenti. Nel caso di demolizione, non esistono particolari pericoli o rischi derivanti dal prodotto stesso. È opportuno, in caso di recupero dei materiali, che vengano separati per tipologia (parti elettriche - rame - alluminio - plastica - ecc.).

### 3) SMANTELLAMENTO

**Attenzione: Avvalersi esclusivamente di personale qualificato.**

Nel caso la centralina venga smontata per essere poi rimontata in altro sito bisogna:

- Togliere l'alimentazione e scollegare tutto l'impianto elettrico.
- Nel caso alcuni componenti non possano essere rimossi o risultino danneggiati, provvedere alla loro sostituzione.

### 4) AVVERTENZE

- Assicurarsi che sia presente sulla rete di alimentazione dell'automazione, un interruttore o un magnetotermico onnipolare con distanza di apertura dei contatti uguale o superiore a 3,5 mm.
- Assicurarsi che sia presente a monte della rete di alimentazione un interruttore differenziale con soglia da 0.03A.
- Assicurarsi che i dispositivi di sicurezza applicati al cancello siano sempre funzionanti, altrimenti togliere alimentazione, sbloccare il motore e rivolgersi subito a personale qualificato.
- Non permettere a persone e bambini di sostare nell'area d'azione dell'automazione.
- Non lasciare radiocomandi o altri dispositivi di comando alla portata dei bambini onde evitare azionamenti involontari dell'automazione.
- L'utilizzatore deve evitare qualsiasi tentativo di intervento o riparazione dell'automazione e rivolgersi solo a personale qualificato.

**Il buon funzionamento dell'attutatore è garantito solo se vengono rispettati i dati riportati in questo manuale. La ditta non risponde dei danni causati dall'inosservanza delle norme di installazione e delle indicazioni riportate in questo manuale.**

**Le descrizioni e le illustrazioni del presente manuale non sono impegnative. Lasciando inalterate le caratteristiche essenziali del prodotto, la Ditta si riserva di apportare in qualunque momento le modifiche che essa ritiene convenienti per migliorare tecnicamente, costruttivamente e commercialmente il prodotto, senza impegnarsi ad aggiornare la presente pubblicazione.**

Thank you for buying this product, our company is sure that you will be more than satisfied with the product's performance. The product is supplied with a "Warnings" leaflet and an "Instruction booklet". These should both be read carefully as they provide important information about safety, installation, operation and maintenance. This product complies with the recognised technical standards and safety regulations. We declare that it is in conformity with the following European Directives: 89/336/EEC, 73/23/EEC and subsequent amendments.

### 1) GENERAL OUTLINE

The ALCOR N mod. control units have been designed to control one single operator.

### 2) SCRAPPING

**Warning: This operation should only be carried out by qualified personnel.** Materials must be disposed of in conformity with the current regulations. In case of scrapping, the automation devices do not entail any particular risks or danger. In case of materials to be recycled, these should be sorted out by type (electrical components, copper, aluminium, plastic etc.).

### 3) DISMANTLING

**Warning: This operation should only be carried out by qualified personnel.** When the control unit is disassembled to be reassembled on another site, proceed as follows:

- Disconnect the power supply and the entire electrical installation.
- In the case where some of the components cannot be removed or are damaged, they must be replaced.

### 4) WARNING

- Make sure that an omnipolar or magnetothermal switch, having a contact opening distance equal to or greater than 3,5 mm, is fitted to the automation power supply mains.
- Make sure that a differential switch with a 0.03A threshold is fitted before the power supply mains.
- Make sure that all safety devices installed on the gate are always in working order; otherwise, disconnect the power supply, release the motors and immediately request assistance from qualified personnel.
- Do not allow persons or children to remain within the automation operation area.
- Keep radio control or other control devices out of children's reach, in order to avoid unintentional automation activation.
- The user must avoid any attempt to carry out work or repair on the automation system, and always request the assistance of qualified personnel.

**Correct controller operation is only ensured when the data contained in the present manual are observed. The company is not to be held responsible for any damage resulting from failure to observe the installation standards and the instructions contained in the present manual.**

**The descriptions and illustrations contained in the present manual are not binding. The Company reserves the right to make any alterations deemed appropriate for the technical, manufacturing and commercial improvement of the product, while leaving the essential product features unchanged, at any time and without undertaking to update the present publication.**

Thank you for buying this product, our company is sure that you will be more than satisfied with its performance.

This product is supplied with an "Instruction Manual" which should be read carefully as it provides important information about safety, installation, operation and maintenance.

This product complies with recognised technical standards and safety regulations. We declare that it is in conformity with the following European Directives: 89/336/EEC, 73/23/EEC and subsequent amendments.

### 1) GENERAL SAFETY

**WARNING! An incorrect installation or improper use of the product can cause damage to persons, animals or things.**

- The "Warnings" leaflet and "Instruction booklet" supplied with this product should be read carefully as they provide important information about safety, installation, use and maintenance.
- Scrap packing materials (plastic, cardboard, polystyrene etc) according to the provisions set out by current standards. Keep nylon or polystyrene bags out of children's reach.
- Keep the instructions together with the technical brochure for future reference.
- This product was exclusively designed and manufactured for the use specified in the present documentation. Any other use not specified in this documentation could damage the product and be dangerous.
- The Company declines all responsibility for any consequences resulting from improper use of the product, or use which is different from that expected and specified in the present documentation.
- Do not install the product in explosive atmosphere.
- The construction components of this product must comply with the following European Directives: 89/336/CEE, 73/23/EEC, 98/37/EEC and subsequent amendments. As for all non-EEC countries, the above-mentioned standards as well as the current national standards should be respected in order to achieve a good safety level.
- The Company declines all responsibility for any consequences resulting from failure to observe Good Technical Practice when constructing closing structures (door, gates etc.), as well as from any deformation which might occur during use.
- The installation must comply with the provisions set out by the following European Directives: 89/336/CEE, 73/23/EEC, 98/37/EEC and subsequent amendments.
- Disconnect the electrical power supply before carrying out any work on the installation. Also disconnect any buffer batteries, if fitted.
- Fit an omnipolar or magnetothermal switch on the mains power supply, having a contact opening distance equal to or greater than 3,5 mm.
- Check that a differential switch with a 0.03A threshold is fitted just before the power supply mains.
- Check that earthing is carried out correctly: connect all metal parts for closure (doors, gates etc.) and all system components provided with an earth terminal.
- Fit all the safety devices (photocells, electric edges etc.) which are needed to protect the area from any danger caused by squashing, conveying and shearing.
- Position at least one luminous signal indication device (blinker) where it can be easily seen, and fix a Warning sign to the structure.
- The Company declines all responsibility with respect to the automation safety and correct operation when other manufacturers' components are used.
- Only use original parts for any maintenance or repair operation.
- Do not modify the automation components, unless explicitly authorised by the company.
- Instruct the product user about the control systems provided and the manual opening operation in case of emergency.
- Do not allow persons or children to remain in the automation operation area.
- Keep radio control or other control devices out of children's reach, in order to avoid unintentional automation activation.
- The user must avoid any attempt to carry out work or repair on the automation system, and always request the assistance of qualified personnel.
- Anything which is not expressly provided for in the present instructions, is not allowed.
- Installation must be carried out using the safety devices and controls prescribed by the EN 12978 Standard.

### 2) GENERAL OUTLINE

ALCOR N mod. control unit has been designed to be applied on swing gates. It can control one or two operators.

### 3) TECHNICAL DATA

Power supply: .....230V±10%, 50Hz(\*)  
 Mains insulation/very low voltage: .....> 4MΩ, 500V~  
 Working temperature: ..... -10 / +55°C

Dielectric strength:.....mains/low voltage 3750V~ for 1 minut  
 Maximum motor power ..... 1 motor 300W  
 .....2 motors 300W + 300W  
 Supply to accessories: ..... 24V~, (0.2A max absorption)  
 Incorporated Rolling-Code radio receiver: ..... Frequency 433.92MHz  
 Coding: ..... Rolling-Code Algorithm to be cloned  
 No. combinations: ..... 4 milliard  
 Antenna impedance:..... 50Ohm (RG58)  
 Max no. radio transmitters to be memorised:..... 63  
 Dimensions: .....see figure 1  
 (\* other voltages available on request)

### 4) TERMINAL BOARD CONNECTIONS (Fig.2)

For the wiring diagram and the cable section, make reference to the operator's manual.

**WARNING** – During the wiring and installation operations, refer to the current standards as well as principles of good technical practice.

Wires powered at different voltages must be physically separated, or suitably insulated with at least 1 mm extra insulation. The wires must be clamped by an extra fastener near the terminals, for example by bands.

All the connection cables must be kept at an adequate distance from the dissipator.

Connect the yellow/green conductor of the power supply cable to the earth terminal. 230V cables must be physically separate from the safety very low voltage circuits. Keep the mains voltage connections definitely separate from the (24V) very low voltage connections.

The capacitors inside the control unit must be positioned in such a way as not to decrease the surface and air distances with respect to the safety very low voltage.

**WARNING! For connection to the mains, use a multipolar cable with a minimum of 3x1.5mm<sup>2</sup> cross section and complying with the previously mentioned regulations. For example, if the cable is out side (in the open), it has to be at least equal to H07RN-F, but if it is on the inside (or outside but placed in a plastic cable channel) it has to be or at least equal to H05VV-F with section 3x1.5mm<sup>2</sup>.**

- 1-2 Power supply 230V +/- 10% 50/60 Hz (Neutral wire to terminal 1).
  - 3-4-5 M1 motor connection (terminal 4 common wire, terminals 3-5 motor and capacitor operation)
  - 1-4 Blinker connection 230V
  - 6-7-8 M2r motor connection (terminal 7 common wire, terminals 6-8 motor and capacitor operation).
  - 1-7 Electric lock connection 230V mod. EBP.
  - 9-10 Input for START Button (N.O.).
  - 9-11 Input for STOP Button (N.C.). If not used, leave bridged.
  - 9-12 Input for Photocell (N.C.). If not used, leave bridged.
  - 9-13 Input with function selectable from DSW9:  
 with DSW9 OFF, Input for Opening Limit Switch (N.C.). If not used, leave bridged.  
 with DSW9 ON Input for OPEN Button (N.O.).\*
  - 9-14 Input with function selectable from DSW9 and DSW10:  
 with DSW9 OFF, Input for Closing Limit Switch (N.C.). If not used, leave bridged.  
 with DSW9 ON and DSW10 OFF, Input for CLOSE Button (N.O.).\*  
 with DSW9 ON and DSW10 ON, Input for PEDESTRIAN Button (N.O.). The pedestrian command is active from gate fully closed; if the gate is not closed, the PEDESTRIAN button carries out the START functions.\*
  - 15-16 Output 24V for accessory power supply 200mA MAX.
  - 17-18 Output for second radio channel, N.O. contact (24V / 1A max.). If an external receiver is used, it must be a double-channel receiver.  
 A dry N.O. contact must be electrically connected to the terminals.
  - 19-20 Input for receiver antenna (20 Braid, 19 Signal).
- \*With operation without limit switches, the motors remain active for the working time set.
- RX Connector for the external receiver board.

### 5) LED (Fig.3)

The ALCOR N control units are provided with a series of self-diagnosis LEDs which control all the functions.

**POWER:** Led for power supply on.

**OP:** Led for Signal indication of Motors active on Opening / Led for Radio Programming.

**CL:** Led for Signal indication of Motors active on Closing.

**START:** It comes on with the START command.

**STOP:** It goes off with the photocells not aligned or in the presence of obstacles.

**SWO:** Led for signal indication of input 13 status:  
 led on= input closed, led off= input open.

**SWC:** Led for signal indication of input 14 status:  
led on= input closed, led off= input open.

## 6) DIP-SWITCH SELECTION (Fig.3)

**DIP1) TCA [ON]** - Automatic closing time TCA.

ON: Activates automatic closing

OFF: Excludes automatic closing

**DIP2) FCH [OFF]** - Photocells.

ON: Photocells are only active in the closing phase. If the photocells are obstructed during closing, the gate reverses its movement and carries out an opening manoeuvre.

OFF: Photocells are active both in the closing and opening phase. If the photocells are obstructed, the gate stops. When the photocells are cleared, the gate resumes its opening manoeuvre.

**DIP3) BLI -[OFF]** Blocks impulses.

ON: START commands are not accepted during the opening phase.

OFF: START commands are accepted during the opening phase.

**DIP4) 3P/4P -[OFF] 3 Steps/4 Steps**

ON: Enables 3-step logic. A start impulse has the following effects:

door closed:.....opens  
on opening:.....stops and enters TCA if configured  
door open:.....closes  
on closing:.....opens  
after stopping:.....opens

OFF: Enables 4-step logic. A start impulse has the following effects:

door closed:.....opens  
on opening:.....stops and enters TCA if configured  
door open:.....closes  
on closing:.....stops and does not enter TCA (stop)  
after stopping:.....opens

**DIP5) CODE FIX [OFF]** – Fixed code.

ON: Activates incorporated receiver in fixed code mode.

OFF: Activates incorporated receiver in rolling-code mode.

**DIP6) RADIO LEARN [OFF]** - Radio transmitter programming

ON: This enables transmitter storage via radio:

1 – First press the hidden key (P1) and then the normal key (T1, T2, T3 or T4) of a transmitter already memorised in standard mode by means of the radio menu.

2 – Within 10s press the hidden key (P1) and the normal key (T1, T2, T3 or T4) of a transmitter to be memorised.

The receiver exits the programming mode after 10s, other new transmitters can be entered before the end of this time.

This mode does not require access to the control panel.

OFF: This disables transmitter storage via radio. The transmitters can only be memorised by pressing the SW1 and SW2 keys (see paragraph 10).

**DIP7) Lock hold [OFF]**

ON: If the motors remain still in a totally open or closed position for over one hour, they are activated for about 3 seconds in the respective direction. This operation takes place once every hour.

**N.B.:** This function has the purpose of compensating any oil volume decrease in the hydraulic motors, due to a temperature drop during prolonged pauses, for instance at night, or to internal leaks.

**IMPORTANT** - When no adequate mechanical backstops are installed, do not use this function. It is also to be absolutely avoided in the automation of sliding gates.

OFF: Excludes the said function.

**DIP8) Ram blow on opening [OFF]**

ON: It pushes for approx. 2 seconds in closing direction before opening. This allows the electric lock to be released more easily (not affected by limit switches).

OFF: Excludes the ram blow in closing.

**IMPORTANT** - When no adequate mechanical backstops are installed, do not use this function. It is also to be absolutely avoided in the automation of sliding gates.

**DIP 9) Function Selection for inputs 13-14 Limit Switches / Buttons**

ON: Inputs 13 and 14 are set as Control button inputs. Input 13 for OPEN button, input 14 according to DSW 10 configuration. With this configuration, the motors remain active for the working time set.

OFF: Inputs 13 and 14 are set as Opening and Closing limit switch inputs, respectively.

**DIP 10) Function Selection for control button inputs 13-14\***

N.B. Only with DSW 9 ON. With DSW 9 OFF, the DSW 10 position has no effect.

OFF: Input 14 configured as CLOSE input.

ON: Input 14 configured as PEDESTRIAN input.

\*If, when the board is activated, the closing limit switch is neither enabled nor operating, at the time of the first manoeuvre neither the ram blow nor the pedestrian opening are carried out.

## 7) TRIMMER ADJUSTMENT (Fig.3)

**TCA** (Dip1 ON).

It is used to set the automatic closing time, after which the gate closes automatically (adjustable from 0 to 120 sec.).

**TW**

It is used to set the motor working time, after which the motor stop (adjustable from 1 to 90 sec.). When using electrical limit switches, increase the motor stopping time by a few seconds with respect to the leaf closing time.

**DELAY M2**

Sets the delay time on closing of motor 2 (M2) (adjustable from 1 to 30 sec.)

## 8) INTEGRATED RECEIVER TECHNICAL SPECIFICATION

Receiver output channels:

- output channel 1, if activated, controls a START command.
- output channel 2, if activated, controls the excitation of the 2nd radio channel relay for 1s.

Transmitter versions which can be used:



all Rolling Code transmitters compatible with

## ANTENNA INSTALLATION

**Use an antenna tuned to 433MHz.**

**For Antenna-Receiver connection, use RG8 coaxial cable.**

The presence of metallic masses next to the antenna can interfere with radio reception. In case of insufficient transmitter range, move the antenna to a more suitable position.

## 9) PROGRAMMING

Transmitter storage can be carried out in manual mode, or by means of the **UNIRADIO** programmer which allows you to create installations in the "collective receivers" mode, as well as manage the complete installation database using the EEDbase software.

## 10) MANUAL PROGRAMMING

In the case of standard installations where no advanced functions are required, it is possible to proceed to manual storage of the transmitters

- 1) If you wish the transmitter T key to be memorised as Start, press the SW1 button on the control unit, otherwise if you wish the transmitter key to be memorised as second radio channel, press the SW2 button on the control unit.
- 2) When the **OP** LED blinks, press the transmitter P1 hidden key, and the **OP** LED will stay on permanently.
- 3) Press the key to be memorised on the transmitter, LED **OP** will start blinking again.
- 4) To memorise another transmitter, repeat steps 2) and 3).
- 5) To exit the storage mode, wait until the LED is switched off completely.

**IMPORTANT NOTE: ATTACH THE ADHESIVE KEY LABEL TO THE FIRST MEMORISED TRANSMITTER (MASTER).**

In the case of manual programming, the first transmitter assigns the key code to the receiver; this code is necessary in order to carry out subsequent cloning of the radio transmitters.

## 10.1) CONTROL UNIT MEMORY CANCELLATION

In order to cancel the control unit memory completely, simultaneously press for 10 seconds the SW1 and SW2 buttons on the control unit (**OP** LED blinking). Correct memory cancellation will be indicated by the **OP** LED staying on permanently. To exit the storage mode, wait until the LED is switched off completely.

## 11) RECEIVER CONFIGURATION

The on-board receiver combines characteristics of utmost safety in copying variable code (rolling code) coding with the convenience of carrying out transmitter "cloning" operations thanks to an exclusive system.

Cloning a transmitter means creating a transmitter which can be automatically included within the list of the transmitters memorised in the receiver, either as an addition or as a replacement of a particular transmitter.

Cloning by replacement is used to create a new transmitter which takes the place of the one previously memorised in the receiver; in this way a specific transmitter can be removed from the memory and will no longer be usable.

Therefore it will be possible to remotely program a large number of additional transmitters or, for example, replacement transmitters for those which have been lost, without making changes directly to the receiver.

When coding safety is not a decisive factor, the on-board receiver allows you to carry out fixed-code additional cloning which, although abandoning the variable code, provides a high number of coding combinations, therefore keeping it possible to "copy" any transmitter which has already been programmed.

## 12) RADIO-TRANSMITTER CLONING (Fig.7)

### Rolling-code cloning / Fixed-code cloning

Make reference to the UNIRADIO Instructions and the CLONIX Programming Guide.

### 12.1) ADVANCED PROGRAMMING: COLLECTIVE RECEIVERS

Make reference to the UNIRADIO Instructions and the CLONIX Programming Guide.

## 13) ACCESSORIES

**SPL** (fig.4). Pre-heating optional board. Recommended for temperatures below  $-10^{\circ}\text{C}$ . (In the case of hydraulic motors).

**ME** (fig.5).

Optional board used to connect a 12V~ electric lock.

**SS (Fig.6/6A) Optional board for gate-open warning light.**

WARNING: only works if electrical limit switches are used.

With the limit switches connected (configuration DSW 9 OFF) use the diagram in figure 6.

With the OPEN - CLOSE/PEDESTRIAN buttons (configuration DSW 9 ON) use the diagram in figure 6A.

**EBP (fig.2).** The EBP electric lock with continuous service can be connected directly to terminals 1 and 4.

## 14) SCRAPPING

**Warning: This operation should only be carried out by qualified personnel.**

Materials must be disposed of in conformity with the current regulations. In case of scrapping, the automation devices do not entail any particular risks or danger. In case of materials to be recycled, these should be sorted out by type (electrical components, copper, aluminium, plastic etc.).

## 15) DISMANTLING

**Warning: this operation should only be carried out by qualified personnel.** When the control unit is disassembled to be reassembled on another site, proceed as follows:

- Disconnect the power supply and the entire electrical installation.
- In the case where some of the components cannot be removed or are damaged, they must be replaced.

**The descriptions and illustrations contained in the present manual are not binding. The Company reserves the right to make any alterations deemed appropriate for the technical, manufacturing and commercial improvement of the product, while leaving the essential product features unchanged, at any time and without undertaking to update the present publication.**

Fig. 1

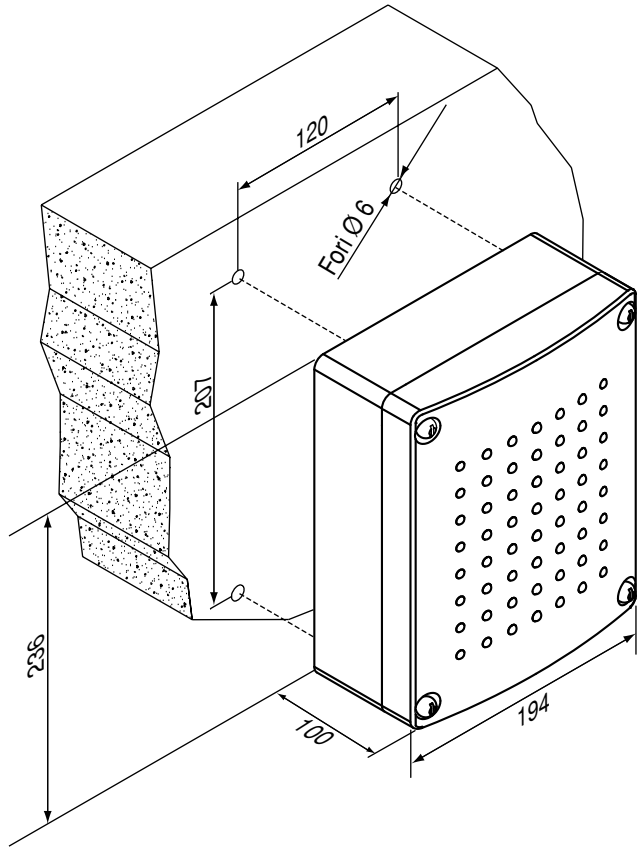

Fig. 3

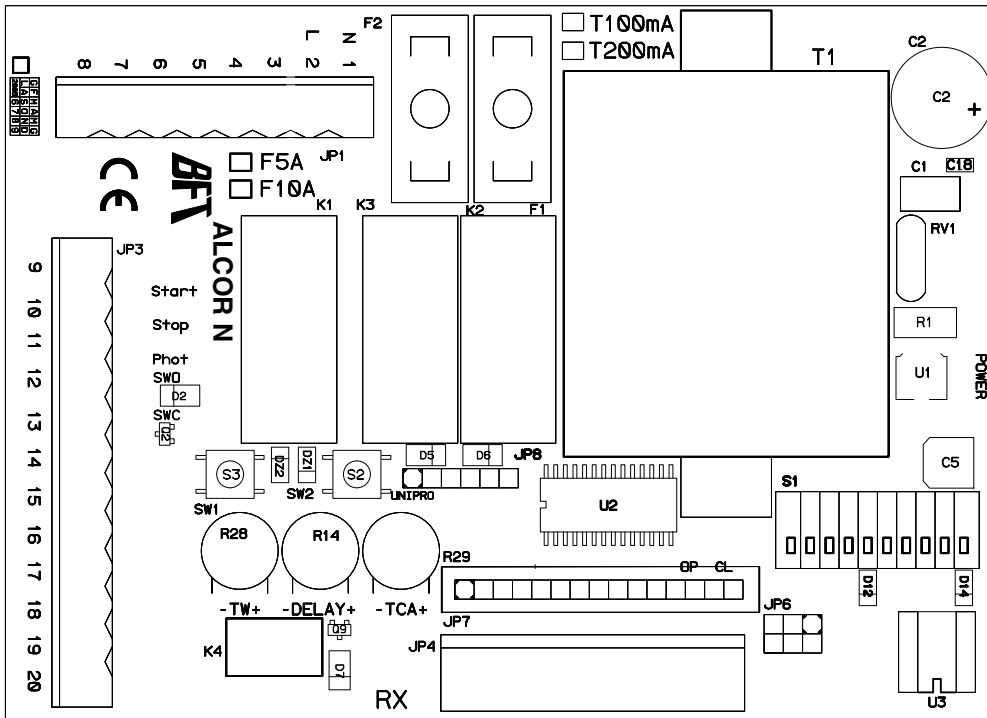

Fig. 2

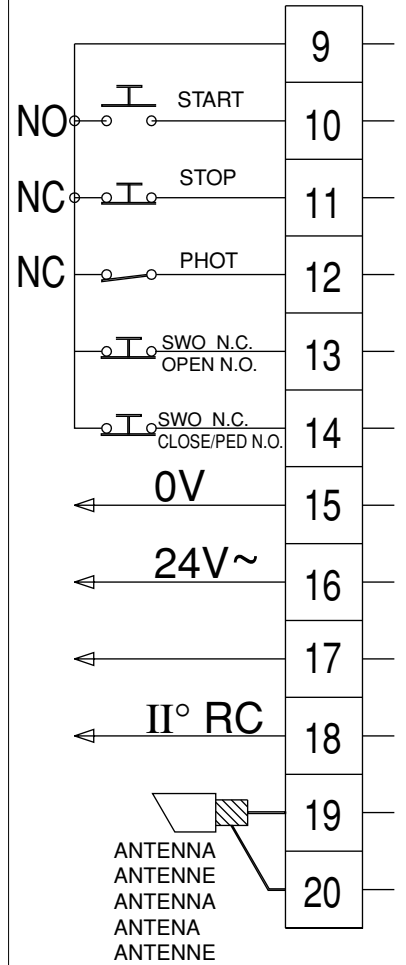
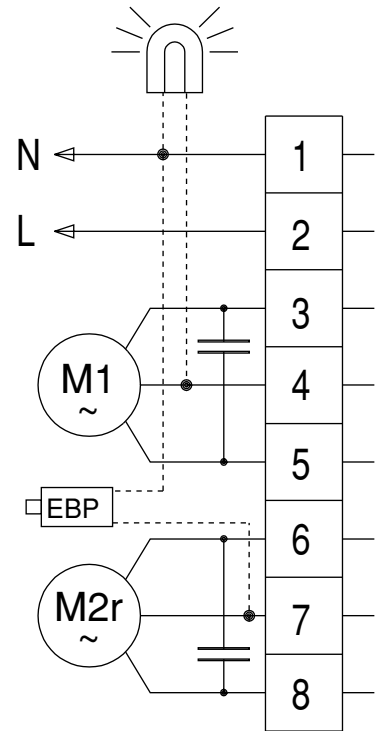

Fig. 4

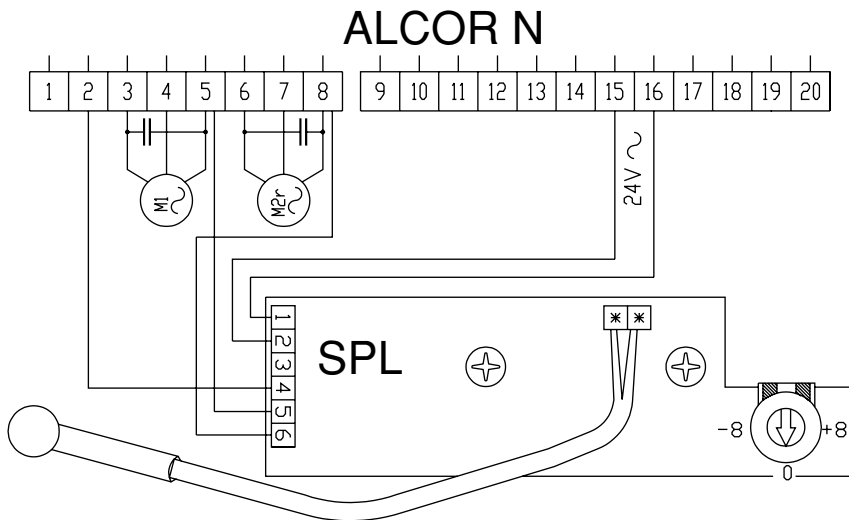

Fig. 5

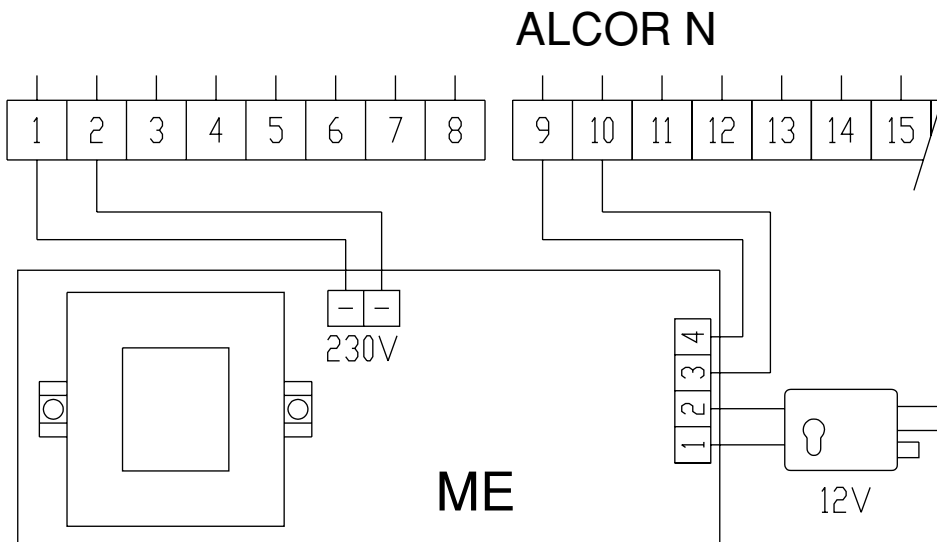

Fig. 6

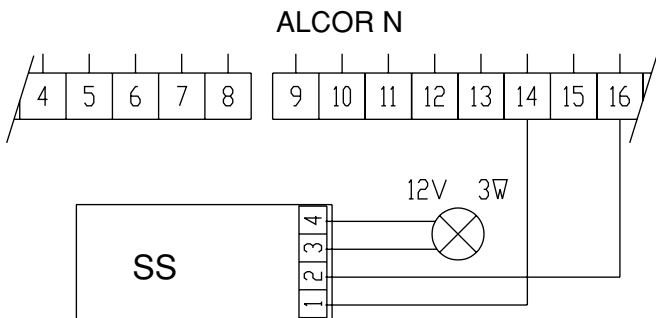

Fig. 6A

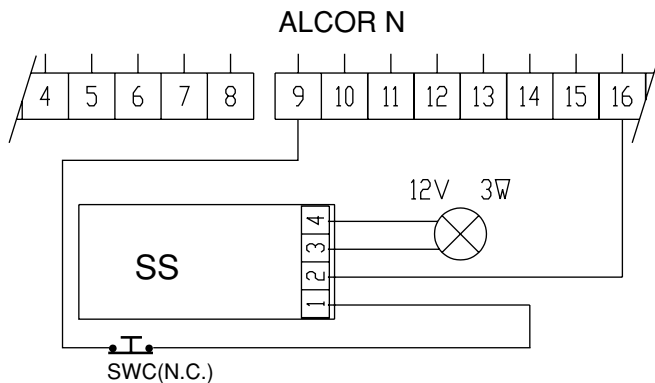
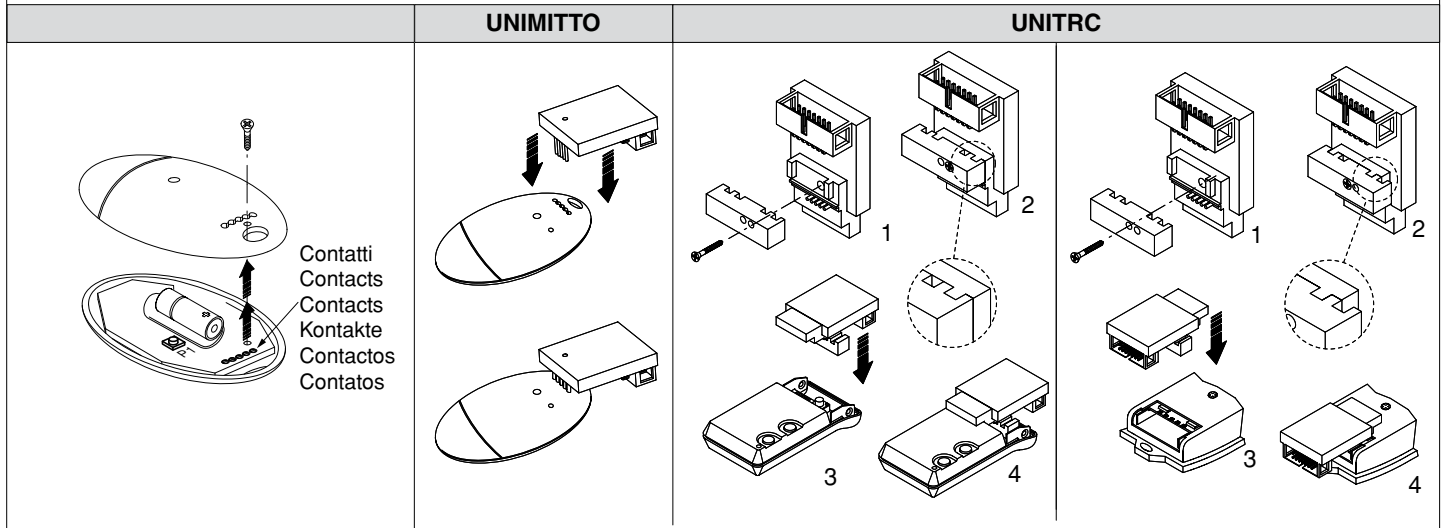
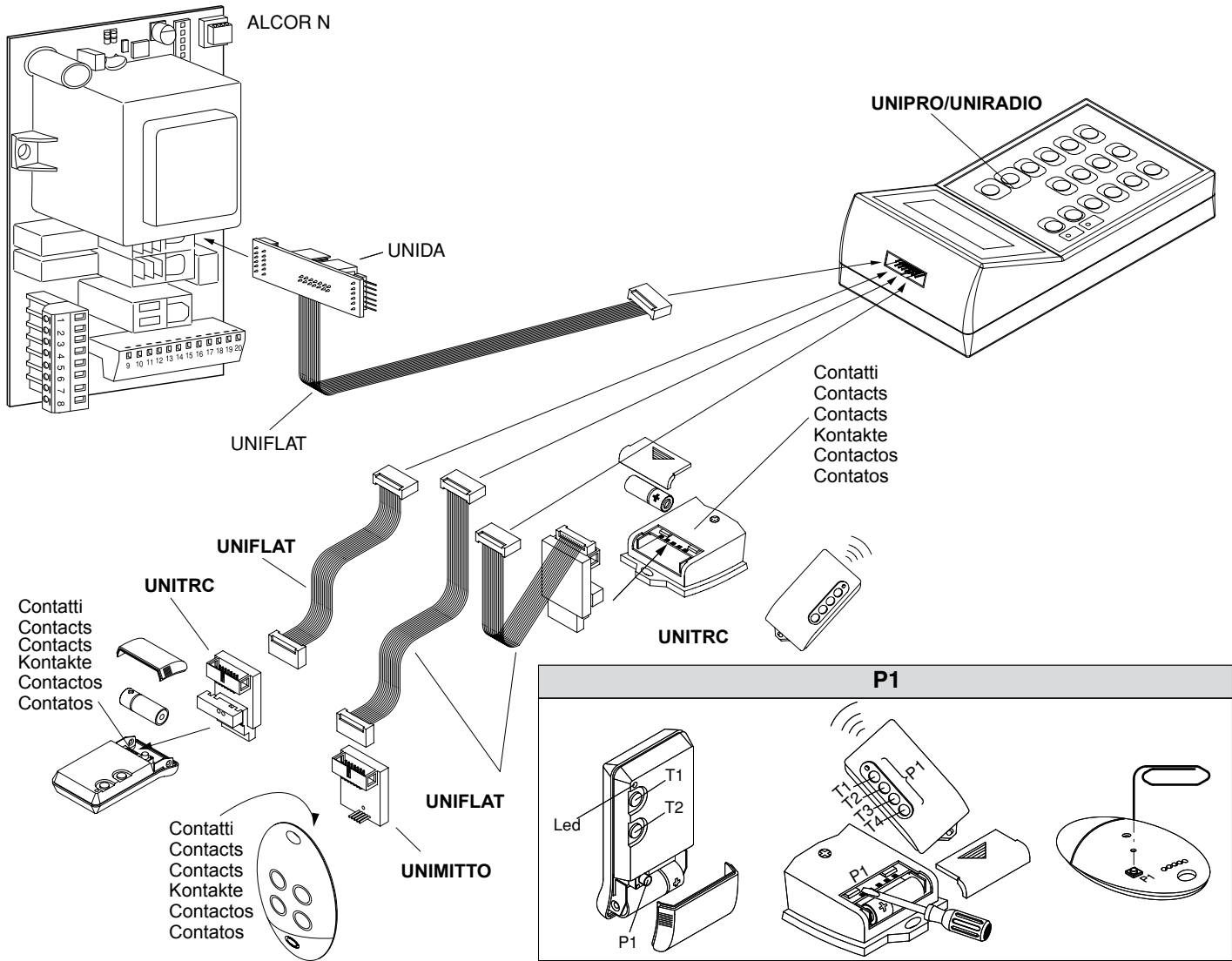



Fig. 7

D811509\_01



**BFT S.P.A.**

Via Lago di Vico 44  
36015 Schio (VI) / *Italy*  
Tel. 0039 445.696511 - Fax 0039 445.696522  
www.bft.it - e-mail: sales@bft.it

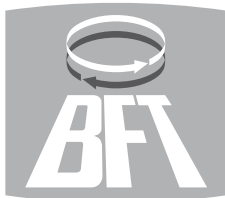
**BFT TORANTRIEBSSYSTEME GmbH**

Faber-Castell Str. 29  
90522 Oberasbach / *Germany*  
Tel. 0049 911 7660090 - Fax 0049 911 7660099  
e-mail: service@bft-torantriebe.de

**BFT AUTOMATION UK LTD**

Unit 8E, Newby Road  
Industrial Estate Hazel Grove  
Stockport SK7 5DA / *England*  
Tel. 0044 161 4560456 - Fax 0044 161 4569090  
e-mail: info@bft.co.uk

**AUTOMATISMES BFT FRANCE**

13 Bdl. E. Michelet  
69008 Lyon / *France*  
Tel. 0033 4 78 76 09 88 - Fax 0033 4 78 76 92 23  
e-mail: infofrance@bft.it

**BFT BENELUX SA**

Rue du commerce 12  
1400 Nivelles / *Belgium*  
Tel. 0032 67/ 55 02 00 - Fax 0032 67/ 55 02 01  
mail: info@bftbenelux.be

**BFT-ADRIA d.o.o.**

Obrovac 39  
51218 Dražice (RIJEKA) / *Croatia*  
Tel. 00385 51 502 640 - Fax 00385 51 502 644  
www.bft.hr - e-mail: info@bft.hr

**BFT Polska Sp. z o.o.**

ul. Szatwiowa 47  
03-167 Warszawa / *Polska*  
Tel. 0048 022 814 12 22 - Fax 0048 022 814 39 18  
www.bft.com.pl - e-mail: biuro@bft.com.pl

**BFT GROUP**

**ITALIBERICA DE AUTOMATISMOS S.L.**  
*España*  
www.bftautomatismos.com

P.I. Palau Nord, Sector F  
C/Cami Can Basa nº 6-8  
08400 GRANOLLERS *Barcelona*  
Telf. +34 93 8614828 - Fax +34 93 8700394  
e-mail: bftbcn@bftautomatismos.com

P.I. Comendador,  
C/ informàtica, Nave 22  
19200 AZUQUECA DE HENARES *Guadalajara*  
Telf. +34 949 26 32 00 - Fax. +34 949 26 24 51  
e-mail: bft@bftautomatismos.com